

User's Manual
Model 648
Electromagnet Power Supply

Lake Shore Cryotronics, Inc.
575 McCorkle Blvd.
Westerville, Ohio 43082-8888 USA

sales@lakeshore.com
service@lakeshore.com
www.lakeshore.com

Fax: (614) 891-1392
Telephone: (614) 891-2243



Methods and apparatus disclosed and described herein have been developed solely on company funds of Lake Shore Cryotronics, Inc. No government or other contractual support or relationship whatsoever has existed which in any way affects or mitigates proprietary rights of Lake Shore Cryotronics, Inc. in these developments. Methods and apparatus disclosed herein may be subject to U.S. Patents existing or applied for.

Lake Shore Cryotronics, Inc. reserves the right to add, improve, modify, or withdraw functions, design modifications, or products at any time without notice. Lake Shore shall not be liable for errors contained herein or for incidental or consequential damages in connection with furnishing, performance, or use of this material.

LIMITED WARRANTY STATEMENT

WARRANTY PERIOD: THREE (3) YEARS

1. Lake Shore warrants that products manufactured by Lake Shore (the "Product") will be free from defects in materials and workmanship for three years from the date of Purchaser's physical receipt of the Product (the "Warranty Period"). If Lake Shore receives notice of any such defects during the Warranty Period and the defective Product is shipped freight prepaid back to Lake Shore, Lake Shore will, at its option, either repair or replace the Product (if it is so defective) without charge for parts, service labor or associated customary return shipping cost to the Purchaser. Replacement for the Product may be by either new or equivalent in performance to new. Replacement or repaired parts, or a replaced Product, will be warranted for only the unexpired portion of the original warranty or 90 days (whichever is greater).
2. Lake Shore warrants the Product only if the Product has been sold by an authorized Lake Shore employee, sales representative, dealer or an authorized Lake Shore original equipment manufacturer (OEM).
3. The Product may contain remanufactured parts equivalent to new in performance or may have been subject to incidental use when it is originally sold to the Purchaser.
4. The Warranty Period begins on the date the Product ships from Lake Shore's plant.
5. This limited warranty does not apply to defects in the Product resulting from (a) improper or inadequate installation (unless OT&V services are performed by Lake Shore), maintenance, repair or calibration, (b) fuses, software, power surges, lightning and non-rechargeable batteries, (c) software, interfacing, parts or other supplies not furnished by Lake Shore, (d) unauthorized modification or misuse, (e) operation outside of the published specifications, (f) improper site preparation or site maintenance (g) natural disasters such as flood, fire, wind, or earthquake, or (h) damage during shipment other than original shipment to you if shipped through a Lake Shore carrier.
6. This limited warranty does not cover: (a) regularly scheduled or ordinary and expected recalibrations of the Product; (b) accessories to the Product (such as probe tips and cables, holders, wire, grease, varnish, feedthroughs, etc.); (c) consumables used in conjunction with the Product (such as probe tips and cables, probe holders, sample tails, rods and holders, ceramic putty for mounting samples, Hall sample cards, Hall sample enclosures, etc.); or, (d) non-Lake Shore branded Products that are integrated with the Product.
7. To the extent allowed by applicable law, this limited warranty is the only warranty applicable to the Product and replaces all other warranties or conditions, express or implied, including, but not limited to, the implied warranties or conditions of merchantability and fitness for a particular purpose. Specifically, except as provided herein,

Lake Shore undertakes no responsibility that the products will be fit for any particular purpose for which you may be buying the Products. Any implied warranty is limited in duration to the warranty period. No oral or written information, or advice given by the Company, its Agents or Employees, shall create a warranty or in any way increase the scope of this limited warranty. Some countries, states or provinces do not allow limitations on an implied warranty, so the above limitation or exclusion might not apply to you. This warranty gives you specific legal rights and you might also have other rights that vary from country to country, state to state or province to province.
8. Further, with regard to the United Nations Convention for International Sale of Goods (CISG,) if CISG is found to apply in relation to this agreement, which is specifically disclaimed by Lake Shore, then this limited warranty excludes warranties that: (a) the Product is fit for the purpose for which goods of the same description would ordinarily be used, (b) the Product is fit for any particular purpose expressly or impliedly made known to Lake Shore at the time of the conclusion of the contract. (c) the Product is contained or packaged in a manner usual for such goods or in a manner adequate to preserve and protect such goods where it is shipped by someone other than a carrier hired by Lake Shore.
9. Lake Shore disclaims any warranties of technological value or of non-infringement with respect to the Product and Lake Shore shall have no duty to defend, indemnify, or hold harmless you from and against any or all damages or costs incurred by you arising from the infringement of patents or trademarks or violation or copyrights by the Product.
10. THIS WARRANTY IS NOT TRANSFERRABLE. This warranty is not transferable.
11. Except to the extent prohibited by applicable law, neither Lake Shore nor any of its subsidiaries, affiliates or suppliers will be held liable for direct, special, incidental, consequential or other damages (including lost profit, lost data, or downtime costs) arising out of the use, inability to use or result of use of the product, whether based in warranty, contract, tort or other legal theory, regardless whether or not Lake Shore has been advised of the possibility of such damages. Purchaser's use of the Product is entirely at Purchaser's risk. Some countries, states and provinces do not allow the exclusion of liability for incidental or consequential damages, so the above limitation may not apply to you.
12. This limited warranty gives you specific legal rights, and you may also have other rights that vary within or between jurisdictions where the product is purchased and/or used. Some jurisdictions do not allow limitation in certain warranties, and so the above limitations or exclusions of some warranties stated above may not apply to you.
13. Except to the extent allowed by applicable law, the terms of this limited warranty statement do not exclude, restrict or modify the mandatory statutory rights applicable to the sale of the product to you.

CERTIFICATION

Lake Shore certifies that this product has been inspected and tested in accordance with its published specifications and that this product met its published specifications at the time of shipment. The accuracy and calibration of this product at the time of shipment are traceable to the United States National Institute of Standards and Technology (NIST); formerly known as the National Bureau of Standards (NBS).

FIRMWARE LIMITATIONS

Lake Shore has worked to ensure that the Model 648 firmware is as free of errors as possible, and that the results you obtain from the instrument are accurate and reliable. However, as with any computer-based software, the possibility of errors exists.

In any important research, as when using any laboratory equipment, results should be carefully examined and rechecked before final conclusions are drawn. Neither Lake Shore nor anyone else involved in the creation or production of this firmware can pay for loss of time, inconvenience, loss of use of the product, or property damage caused by this product or its failure to work, or any other incidental or consequential damages. Use of our product implies that you understand the Lake Shore license agreement and statement of limited warranty.

FIRMWARE LICENSE AGREEMENT

The firmware in this instrument is protected by United States copyright law and international treaty provisions. To maintain the warranty, the code contained in the firmware must not be modified. Any changes made to the code is at the user's risk. Lake Shore will assume no responsibility for damage or errors incurred as result of any changes made to the firmware.

Firmware License Agreement, continued:

Under the terms of this agreement you may only use the Model 648 firmware as physically installed in the instrument. Archival copies are strictly forbidden. You may not decompile, disassemble, or reverse engineer the firmware. If you suspect there are problems with the firmware, return the instrument to Lake Shore for repair under the terms of the Limited Warranty specified above. Any unauthorized duplication or use of the Model 648 firmware in whole or in part, in print, or in any other storage and retrieval system is forbidden.

TRADEMARK ACKNOWLEDGMENT

Many manufacturers and sellers claim designations used to distinguish their products as trademarks. Where those designations appear in this manual and Lake Shore was aware of a trademark claim, they appear with initial capital letters and the ™ or ® symbol.

Alumel™ and Chromel™ are trademarks of Conceptech, Inc., Corporation

CalCurve™, Cernox™, SoftCal™, Rox™, Curve Handler™ are trademarks of Lake Shore Cryotronics, Inc.

Java™ is a registered trademark of Sun Microsystems, Inc. of Santa Clara, CA

LabVIEW® is a registered trademark of National Instruments.

Mac® is a registered trademark of Apple, Inc., registered in the U.S and other countries.

Microsoft Windows®, Excel®, and Windows Vista® are registered trademarks of Microsoft Corporation in the United States and other countries.

Stycast® is a trademark of Emerson & Cuming.

WinZip™ is a registered trademark of Nico Mak of Connecticut.

Copyright 2012-2019 Lake Shore Cryotronics, Inc. All rights reserved. No portion of this manual may be reproduced, stored in a retrieval system, or transmitted, in any form or by any means, electronic, mechanical, photocopying, recording, or otherwise, without the express written permission of Lake Shore.



EU DECLARATION OF CONFORMITY



This declaration of conformity is issued under the sole responsibility of the manufacturer.

Manufacturer:

Lake Shore Cryotronics, Inc.
575 McCorkle Boulevard
Westerville, OH 43082
USA

Object of the declaration:

Model(s): 648
Description: Electromagnet Power Supply

The object of the declaration described above is in conformity with the relevant Union harmonization legislation:

2014/35/EU Low Voltage Directive
2014/30/EU EMC Directive
2011/65/EU RoHS

References to the relevant harmonized standards used to the specification in relation to which conformity is declared:

EN 61010-1:2010
Overvoltage Category II
Pollution Degree 2

EN 61326-1:2013
Class A
Controlled Electromagnetic Environment

EN 50581:2012

Signed for and on behalf of:

Place, Date:
Westerville, OH USA
29-SEP-2016



Scott Ayer
Director of Quality & Compliance

Electromagnetic Compatibility (EMC) for the Model 648 Electromagnet Power Supply

Electromagnetic Compatibility (EMC) of electronic equipment is a growing concern worldwide. Emissions of and immunity to electromagnetic interference is now part of the design and manufacture of most electronics. To qualify for the CE Mark, the Model 648 meets or exceeds the requirements of the European EMC Directive 89/643/EEC as a CLASS A product. A Class A product is allowed to radiate more RF than a Class B product and must include the following warning:

WARNING:This is a Class A product. In a domestic environment, this product may cause radio interference in which case the user may be required to take adequate measures.

The instrument was tested under normal operating conditions with sensor and interface cables attached. If the installation and operating instructions in the User's Manual are followed, there should be no degradation in EMC performance.

This instrument is not intended for use in close proximity to RF Transmitters such as two-way radios and cell phones. Exposure to RF interference greater than that found in a typical laboratory environment may disturb the sensitive measurement circuitry of the instrument.

Pay special attention to instrument cabling. Improperly installed cabling may defeat even the best EMC protection. For the best performance from any precision instrument, follow the grounding and shielding instructions in the User's Manual. In addition, the installer of the Model 648 should consider the following:

- Shield measurement and computer interface cables.
- Leave no unused or unterminated cables attached to the instrument.
- Make cable runs as short and direct as possible. Higher radiated emissions are possible with long cables.
- Do not tightly bundle cables that carry different types of signals.
- When the instrument is subjected to EM fields of 1 V/m, the output voltage reading may shift as much as $\pm 0.1V$.

Table of Contents

Chapter 1 Introduction	1.1 Product Description	1
	1.2 Output Architecture	2
	1.3 Output Programming	2
	1.4 Output Reading	2
	1.5 Protection	2
	1.6 Interfaces	2
	1.7 Display and Keypad	2
	1.8 3-Year Warranty and Technical Support	2
	1.9 Model 648 Specifications	3
	1.10 Ordering Information	6
	1.11 Safety Summary and Symbols	7
Chapter 2 Magnet System Design, Installation, and Operation	2.1 General	9
	2.2 Major Components of the Magnet	9
	2.3 Magnet Construction	10
	2.4 Connecting the Magnet	10
	2.4.1 Water Hose Connection	10
	2.4.2 Magnet Coil Wiring	11
	2.4.3 Temperature Switches and Flow Switches	12
	2.4.4 Cooling Water and Water Valve	12
	2.4.5 Grounding	13
	2.4.6 Final Check-Out	13
	2.5 Electromagnet Operation	13
	2.5.1 Air Gap and Pole Caps	13
	2.5.2 Maximum Current and Power	13
2.5.3 Operation Under Field Control	15	
2.5.4 Avoiding Cooling Water Condensation	15	
Chapter 3 Installation	3.1 General	17
	3.2 Inspection and Unpacking	17
	3.2.1 Moving and Handling	18
	3.3 Rear Panel Definition	18
	3.4 Power Wiring and Setup	19
	3.4.1 Line Voltage Selection	20
	3.4.2 Circuit Breaker Setting	20
	3.4.3 Start-up Fuses	21
	3.4.4 Cable Entry	21
	3.4.5 Power Input Terminals	23
	3.4.6 Wiring Cover	24
	3.4.7 Mains Wiring	25
	3.5 Magnet Connector	25
	3.6 Auxiliary Connector	25
3.7 Power Supply Connector	26	
3.8 Cooling Water	26	
3.9 Magnet Cable Connections	28	
3.10 Analog Input/Output Connections	29	
3.10.1 External Current Programming	29	
3.10.2 Output Current and Voltage Monitors	29	
3.11 Computer Interface	29	
3.11.1 USB Interface Connection	29	
3.11.2 IEEE-488 Interface Connection	30	

3.12 Chassis Connection	30
3.12.1 3-Phase Power Connections	30
3.12.2 Attach the Floor Mounting Option	30

Chapter 4 Operation

4.1 General	31
4.1.1 Understanding Menu Navigation	31
4.2 Turning Power On	31
4.3 Display Definition	32
4.4 LED Annunciators	32
4.4.1 Fault LED	33
4.4.2 Compliance LED	33
4.4.3 Power Limit LED.....	33
4.4.4 Ramping LED.....	33
4.4.5 Remote LED	33
4.5 Keypad Definition	33
4.5.1 General Keypad Operation	34
4.6 Display Setup	35
4.7 Setting Output Current.....	35
4.8 Output Current Ramp Rate	35
4.9 Ramp Segments	36
4.9.1 Setting Up the Ramp Segments Table	36
4.10 Pause Output	36
4.11 Zero Output	37
4.12 Maximum Setting Limits	37
4.12.1 Maximum Output Current	37
4.12.2 Maximum Current Ramp Rate	37
4.13 Magnet Water	37
4.14 Internal Water	38
4.15 Error Status Display	38
4.16 External Current Programming	39
4.17 Locking the Keypad	39
4.18 Computer Interface	40
4.18.1 Changing IEEE-488 Interface Parameters	40
4.19 Default Parameter Values	40

Chapter 5 Computer Interface Operation

5.1 General	41
5.2 IEEE-488 Interface	41
5.2.1 Changing IEEE-488 Interface Parameters	42
5.2.2 Remote/Local Operation	42
5.2.3 IEEE-488 Command Structure	42
5.2.3.1 Bus Control Commands	42
5.2.3.2 Common Commands.....	43
5.2.3.3 Device Specific Commands	43
5.2.3.4 Message Strings	43
5.2.4 Status System Overview	44
5.2.4.1 Condition Registers	44
5.2.4.2 Event Registers	44
5.2.4.3 Enable Registers	44
5.2.4.4 Status Byte Register	46
5.2.4.5 Service Request Enable Register	47
5.2.4.6 Reading Registers	47
5.2.4.7 Programming Registers	47
5.2.4.8 Clearing Registers	47
5.2.5 Status System Detail: Status Register Sets	47
5.2.5.1 Standard Event Status Register Set	48
5.2.5.2 Operation Event Register Set	48
5.2.6 Status System Detail: Error Status Register Sets	49

Chapter 6 Service

5.2.6.1	Hardware Error Status Register Set	49
5.2.6.2	Operational Error Status Register Set	50
5.2.7	Status System Detail: Status Byte Register and Service Request (SRQ)	51
5.2.7.1	Status Byte Register	51
5.2.7.2	Service Request Enable Register	52
5.2.7.3	Using Service Request (SRQ) and Serial Poll	52
5.2.7.4	Using Status Byte Query (*STB?)	53
5.2.7.5	Using Message Available (MAV) Bit	53
5.2.7.6	Using Operation Complete (*OPC) and Operation Complete Query (*OPC?)	53
5.3	Serial Interface Overview	54
5.3.1	Physical Connection	54
5.3.2	Hardware Support	54
5.3.3	Installing the USB Driver	54
5.3.3.1	Installing the Driver From Windows® Update in Windows Vista® and Windows 7®	55
5.3.3.2	Installing the Driver From Windows® Update in Windows® XP	55
5.3.3.3	Installing the Driver From the Web	55
5.3.3.3.1	Download the driver	55
5.3.3.3.2	Extract the driver	55
5.3.3.3.3	Manually install the driver	56
5.3.3.4	Installing the USB Driver from the Included CD	57
5.3.4	Communication	58
5.3.4.1	Character Format	58
5.3.4.2	Message Strings	58
5.3.5	Message Flow Control	58
5.4	Command Summary	59
6.1	General	69
6.2	USB Troubleshooting	69
6.2.1	New Installation	69
6.2.2	Existing Installation No Longer Working	69
6.2.3	Intermittent Lockups	69
6.3	IEEE Interface Troubleshooting	70
6.3.1	New Installation	70
6.3.2	Existing Installation No Longer Working	70
6.3.3	Intermittent Lockups	70
6.4	Fuse Drawer	70
6.5	Line Voltage Selection	71
6.6	Circuit Breaker Setting	72
6.7	Power Line Fuse Replacement	73
6.8	Factory Reset Menu	74
6.8.1	Default Values	74
6.9	Error Messages	74
6.9.1	Types of Error Messages	74
6.10	Calibration Procedure	75
6.11	Connector and Cable Definitions	76
6.11.1	Analog I/O Connector	76
6.11.2	Magnet Water Connector	76
6.11.3	Auxiliary Connector	77
6.11.4	Power Supply Water Connectors	78
6.11.4.1	Flow Switch	78
6.11.4.2	Water Control Valve	78
6.11.5	USB Connector	79
6.12	Technical Inquiries	79
6.12.1	Contacting Lake Shore	79
6.12.2	Return of Equipment	80

6.12.3 RMA Valid Period	80
6.12.4 Shipping Charges	80
6.12.5 Restocking Fee	80

Chapter 1: Introduction

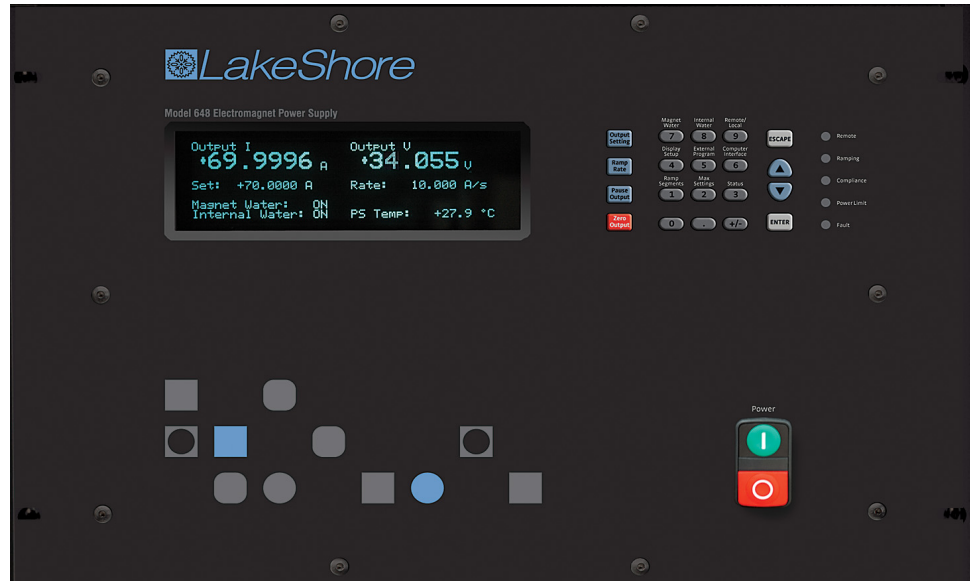

FIGURE 1-1 Model 648 front view

1.1 Product Description

Features:

- Bipolar, linear, true 4-quadrant output
- $\pm 135\text{ A}/\pm 75\text{ V}$, 9.1 kW
- Low noise
- 1 mA of programmed current resolution
- Analog programming and IEEE-488 and USB interfaces
- Built-in fault protection

The Model 648 electromagnet power supply is a robust, fault-tolerant 9 kW supply optimized for powering large 7 or 10 in research electromagnets. It is specifically designed for high precision laboratory use requiring extremely low electrical noise. The linear design removes undesirable higher frequency noise typical of switch mode power supplies. Eliminating the need for external switching or operator intervention to reverse current polarity, the Model 648 uses convenient bipolar, 4-quadrant operation. It is capable of supplying $\pm 135\text{ A}/\pm 75\text{ V}$ to a nominal 0.5 Ω , 0.5 H load. The Model 648 is built to last with a rugged design, integrated fault protection, and a simple, clean interior electronic design.

This robust power supply is developed to minimize downtime. It uses worry-free water cooling for quiet efficient operation compared to air-cooled power supplies. The seamless water lines only have external junctions, eliminating internal water leaks. In addition, safety interlocks ensure that magnet cooling water is always flowing to the supply while operating. Water can be interlocked into the power supply if desired. Internal software controls manage water usage intelligently.

When combined with a Lake Shore EM7 7-inch electromagnet and Model 475 DSP gaussmeter, the Model 648 forms a versatile electromagnet characterization system ideal for a wide range of user defined applications, including magneto-optical studies, magnetic hysteresis tests, susceptibility measurements, Hall effect studies, spin magnetic resonance demonstrations, and biological tests.

1.2 Output Architecture

The low electrical noise design of the Model 648 makes it the ideal power supply for use with large electromagnets in high precision laboratory settings, ensuring greater resolution and finer detail in data taken during highly sensitive measurements. Since low noise is critical to measurement systems, the Model 648 implements both a linear design and bipolar architecture. Linear magnet power supplies have several advantages over switch mode power supplies, primarily smooth field generation that is nearly free from offending electromagnetic signatures. The bipolar, 4-quadrant operation required to safely operate an inductive load provides clean transitions through zero without discontinuities.

1.3 Output Programming

The Model 648 output current is programmed internally via the keypad or the computer interface, externally by analog programming input, or by the sum of the external and internal settings. External programming via analog input signal provides analog resolution. The Model 648 generates extremely smooth and continuous ramps—the digitally generated constant current ramp rate is variable between 0.1 mA/s and 50.000 A/s. To ensure a smooth ramp rate, the power supply updates the high-resolution DAC 12.3 times per second.

1.4 Output Reading

The Model 648 provides high-resolution output current readings that reflect the actual current in the magnet, and have a resolution of 1 mA. The output voltage reading reports the voltage at the output terminals with a resolution of 1 mV. All output readings can be prominently displayed on the front panel and read over the computer interface.

1.5 Protection

The Model 648 provides built-in protection against short circuit, open circuit, line loss, low line voltage, high line voltage, output over voltage, output over current, over temperature, and abrupt change of the external programming input. A proprietary circuit limits the power dissipated in the water-cooled cold plate should low resistance and high line conditions exist. The Model 648 protects itself if operated into resistances outside of nominal limits. By limiting current output, it will safely operate into a shorted load, and operate safely into high resistance loads by limiting voltage output. The Model 648 is also protected against power loss under full operation and nominal magnet load. Both low and high power line conditions are reported on the front panel display.

1.6 Interfaces

The Model 648 includes both parallel IEEE-488 and universal serial bus (USB) computer interfaces that provide access to operating data, stored parameters, and remote control of all front panel operating functions. The USB interface emulates an RS-232C serial port at a fixed 57,600 baud rate, but with the physical connections of a USB. This allows you to download firmware upgrades, ensuring your supply is using the most current firmware version with no need for any physical changes. The Model 648 also provides two analog monitors for output current and voltage.

1.7 Display and Keypad

The Model 648 has a large screen displaying output current and output voltage readings simultaneously. Five front panel LEDs provide quick verification of instrument status, including ramping, compliance, fault, power limit, and computer interface mode. Error conditions are indicated on the main display along with an audible beeper. The most common functions of the power supply are accessed using a single button press.

1.8 3-Year Warranty and Technical Support

The Model 648 is supported by a 3-year standard warranty, our confirmation of quality and commitment for the long term. Our physicists understand your applications and measurements and provide support throughout your decision making process and beyond the sale.

1.9 Model 648 Specifications

1.9.1 Output

Type: Bipolar, 4-quadrant, DC voltage/current source
Current generation: Fully linear regulation with digital setting and analog control
Current range: ± 135 A
Compliance voltage (DC): ± 75 V
Power: 9.1 kW nominal
Nominal load: 0.5 Ω , 0.5 H
Maximum load resistance: 0.55 Ω for ± 135 A DC operation
Minimum load resistance: 0.41 Ω for ± 135 A DC operation
Load inductance range: 0 H to 1 H
Current ripple: 10 mA RMS (0.007%) at 135 A into nominal load
Current ripple frequency: Dominated by the line frequency and its harmonics
Temperature coefficient: ± 50 ppm of full scale/ $^{\circ}$ C
Line regulation: ± 75 ppm of full scale/10% line change
Stability (1 h): 2 mA/h (after warm-up, internal setting)
Stability (24 h): 10 mA/24 h (typical, internal setting, dominated by temperature coefficient and line regulation)
Isolation: Differential output is optically isolated from chassis to prevent ground loops
Slew rate: 50 A/s into nominal load (dominated by magnet characteristics), 100 A/s maximum into a resistive load
Settling time: < 1 s for 10% step to within 1 mA of output into nominal load
Harmonic distortion: ≤ 0.1 Hz at ± 135 A sine wave into resistive load, $< 0.02\%$ THD; ≤ 10 Hz at ± 10 A sine wave into resistive load, $< 0.30\%$ THD
Attenuation: -0.5 dB at 10 Hz (external programming input)
Protection: Short circuit, line loss, low line voltage, high line voltage, output over voltage, output over current, and over temperature
Connector: Two lugs with 8.64 mm (0.34 in) holes for M8 or 5/16 in bolts

1.9.2 Output Programming

Internal current setting
Resolution: 1.0 mA (20-bit)
Settling time: 600 ms for 1% step to within 1 mA (of internal setting)
Accuracy: ± 20 mA $\pm 0.05\%$ of setting
Operation: Keypad, computer interface
Protection: Programmable current setting limit

Internal current ramp
Ramp rate: 0.1 mA/s to 50.000 A/s (compliance limited)
Update rate: 12.3 increments/s
Ramp segments: 5
Operation: Keypad, computer interface
Protection: Programmable ramp rate limit

External current programming
Sensitivity: 10 V/135 A
Resolution: Analog
Accuracy: ± 20 mA $\pm 1\%$ of setting
Input resistance: 20 k Ω differential, 50 k Ω common-mode
Operation: Voltage program through rear panel, can be summed with internal current setting
Limits: Internally clamped at ± 10.1 V and bandwidth limited -3 dB at 40 Hz (2 pole, low pass filter)
Connector: Shared 15-pin D-sub

1.9.3 Readings**Output current**

Resolution: 1.0 mA

Accuracy: ± 20 mA $\pm 0.05\%$ of rdg

Update rate: 2.5 rdg/s display, 10 rdg/s interface

Output voltage (at supply terminals)

Resolution: 1.0 mV

Accuracy: ± 10 mV $\pm 0.05\%$ of rdg

Update rate: 2.5 rdg/s display, 5 rdg/s interface

1.9.4 Front Panel**Display type:** 8-line by 40-character graphic vacuum fluorescent display module**Display readings:** Output current, output voltage, and internal water temperature**Display settings:** Output current and ramp rate**Display annunciators:** Status and error conditions**LED annunciators:** Fault, Compliance, Power Limit, Ramping, Remote**Audible annunciator:** Errors and faults**Keypad type:** 20 full travel keys**Keypad functions:** Direct access to common operations, menu-driven setup**Power:** Green flush ON and red extended OFF push buttons**1.9.5 Interface****IEEE-488.2 interface****Features:** SH1, AH1, T5, L4, SR1, RL1, PPO, DC1, DTO, CO, E1**Reading rate:** To 10 rdg/s**Software support:** National Instruments LabVIEW™ driver (consult Lake Shore for availability)**USB interface****Function:** Emulates a standard RS-232 serial port**Baud rate:** 57,600**Reading rate:** To 10 rdg/s**Connector:** Type B USB connector**Software support:** National Instruments LabVIEW™ driver (consult Lake Shore for availability)**Output current monitor****Sensitivity:** 7 V/135 A**Accuracy:** $\pm 1\%$ of full scale**Noise:** 5 mV RMS**Source impedance:** 20 Ω **Connector:** Shared 15-pin D-sub**Output voltage monitor****Sensitivity:** 7 V/70 V**Accuracy:** 1% of full scale**Noise:** 2 mV RMS**Source impedance:** 20 Ω **Connector:** Shared 15-pin D-sub**Power supply cooling water****Remote enable input:** TTL low or contact closure to enable output; used for mandatory 1 gal/min flow switch (included)**Connector:** 2-pin detachable terminal block connector**Valve power output:** 24 VAC at 1.5 A maximum, automatic or manual control**Connector:** 2-pin detachable terminal block connector

Water valve optional

Magnet cooling water

Remote enable input: TTL low or contact closure to enable output; jumper required if unused

Valve power output: 24 VAC at 1.5 A maximum, automatic or manual control

Connector: Shared 4-pin detachable terminal block

Flow, temperature switch, and water valve not included

Auxiliary

Emergency stop: Requires 1 A, 24 VAC normally closed (NC) contact to enable power-up; jumper required if unused

Fault output: Relay with normally open (NO) or normally closed (NC) contact, 30 VDC at 1 A

Remote enable input: TTL low or contact closure to enable output; jumper required if unused

Connector: Shared 8-pin detachable terminal block

Emergency stop and inhibit switches not included

1.10 General**Line power**

Power: 15.5 kVA max

Voltage and current: 200 VAC $\pm 5\%$, 41 A/phase; 208 VAC $\pm 5\%$, 40 A/phase;

220 VAC $\pm 5\%$, 38 A/phase; 230 VAC $\pm 5\%$, 37 A/phase; 380 VAC $\pm 5\%$, 23 A/phase;

400 VAC $\pm 5\%$, 21 A/phase; 415 VAC $\pm 5\%$, 21 A/phase

Protection: 3-phase thermal relay with adjustable current setting; two class CC 2 A fuses; over-voltage lockout circuit

Frequency: 50 Hz or 60 Hz

Configuration: 3-phase delta

Connector: 4-pin terminal block

Line voltage must be specified at time of order but is field reconfigurable; cable from power supply to facility power not included

Cooling water

Flow rate: 7.6 L (2.0 gal)/min minimum

Maximum pressure: 552 kPa (80 psi)

Pressure drop: 159 kPa (23 psi) at 7.6 L (2.0 gal)/min minimum for power supply and mandatory flow switch

Temperature: 15 °C to 30 °C (non-condensing)

Connection: Two 12.7 mm (0.5 in) hose barbs



Internal condensation can cause damage to the power supply

Enclosure type: Custom 19 in rack cabinet

Size: 559 mm W x 673 mm D x 1054 mm H (22 in W x 26 in D x 42 in H)

Weight: 225 kg (495 lb)

Shipping size: 914 mm W x 1168 mm D x 1219 mm H (36 in x 46 in x 48 in)

Shipping weight: 281 kg (620 lb)

Ambient temperature: 15 °C to 35 °C at rated accuracy, 5 °C to 40 °C at reduced accuracy

Humidity: Non-condensing

Warm-up: 30 min at output current setting

Approvals: CE mark-low voltage compliance to EN61010-1, EMC compliance to EN61326-1

1.11 Ordering Information

Part number	Description
648-200	Model 648 ± 135 A ± 76 V, 9.1 kW, 200 VAC
648-208	Model 648 ± 135 A ± 76 V, 9.1 kW, 208 VAC
648-220	Model 648 ± 135 A ± 76 V, 9.1 kW, 220 VAC
648-230	Model 648 ± 135 A ± 76 V, 9.1 kW, 230 VAC
648-380	Model 648 ± 135 A ± 76 V, 9.1 kW, 380 VAC
648-400	Model 648 ± 135 A ± 76 V, 9.1 kW, 400 VAC
648-415	Model 648 ± 135 A ± 76 V, 9.1 kW, 415 VAC

All specifications are subject to change without notice

TABLE 1-1 Model 648

Part number	Description
6051	Terminal block, 4-pin
6052	Terminal block, 8-pin
6252	15-pin D-sub mating connector, analog I/O
—	Hose clamps
—	Power cable strain relief (power cable not included)
—	Calibration certificate
MAN-Model 648	Model 648 user manual

TABLE 1-2 Model 648 accessories included

Part number	Description
6043	Water valve
117-017	1 m (3.3 ft long) IEEE-488 (GPIB) computer interface cable assembly
CAL-648-CERT	Instrument recalibration with certificate
CAL-648-DATA	Instrument recalibration with certificate and data

All specifications are subject to change without notice

TABLE 1-3 Model 648 accessories available

1.12 Safety Summary and Symbols

Observe these general safety precautions during all phases of instrument operation, service, and repair. Failure to comply with these precautions or with specific warnings elsewhere in this manual violates safety standards of design, manufacture, and intended instrument use. Lake Shore Cryotronics, Inc. assumes no liability for Customer failure to comply with these requirements.

The Model 648 protects the operator and surrounding area from electric shock or burn, mechanical hazards, excessive temperature, and spread of fire from the instrument. Environmental conditions outside of the conditions below may pose a hazard to the operator and surrounding area.

- Indoor use
- Altitude to 2000 m
- Temperature for safe operation: 5 °C to 40 °C
- Maximum relative humidity: 80% for temperature up to 31 °C decreasing linearly to 50% at 40 °C
- Power supply voltage fluctuations not to exceed $\pm 10\%$ of the nominal voltage
- Overvoltage category II
- Pollution degree 2

Power and Ground Connections

This instrument must be connected to a dedicated three-phase power circuit with proper size of circuit breaker (refer to Chapter 3). The connection installation must be performed by a licensed electrician. Verify that the unit has been configured for the correct input voltage. The neutral line, if available, is not used. Power to the unit must be hard-wired, and never connected using a detachable cord. In all cases the correct size wire must be chosen for the current drawn, working voltage, and the length of cable used. To minimize shock hazard, the electrical ground (safety ground) lead must be connected. Power wiring must comply with electrical codes of the locality in which the unit is installed.

Ventilation

The instrument has an exhaust fan and ventilation holes on the rear panel. Do not block these holes when the instrument is operating. Provide at least 25 mm (1 in) of air space on each side for ventilation.

Do Not Operate in an Explosive Atmosphere

Do not operate the instrument in the presence of flammable gases or fumes. Operation of any electrical instrument in such an environment constitutes a definite safety hazard.

Keep Away from Live Circuits

Operating personnel must not remove instrument covers. Refer component replacement and internal adjustments to qualified maintenance personnel. Do not replace components with power cable connected. To avoid injuries, always disconnect power and discharge circuits before touching them.

Do Not Substitute Parts or Modify Instrument

Do not install substitute parts or perform any unauthorized modification to the instrument. Return the instrument to an authorized Lake Shore Cryotronics, Inc. representative for service and repair to ensure that safety features are maintained.

Do not Use the Equipment In a Manner Not Specified

If the equipment is used in a manner not specified by the manufacturer, the safety protection provided by the equipment may be impaired.

Prevent Cooling Water Condensation

Do not operate the power supply when cooling water temperature is at or lower than the dew point for local atmospheric conditions. Condensation on cooling water lines inside the power supply can cause severe damage. Refer to section 2.5.4 for additional details.

Cleaning

Do not submerge instrument. Clean only with a damp cloth and mild detergent. Exterior only.

Moving and Handling

Casters are installed on the base to allow the unit to be rolled around. Four lifting lugs are provided for ease of moving and handling the Model 648. Always use all four lifting lugs when lifting the unit. Because of its weight, the Model 648 should be handled by mechanical means.

CAUTION

To avoid injury to personnel, always observe proper lifting techniques in accordance with OSHA and other regulatory agencies.













	Direct current		On (supply)
	Alternating current		Off (supply)
	Both direct and alternating current		Equipment protected throughout by double insulation or reinforced insulation (equivalent to Class II of IEC 536—see Annex H)
	Three-phase alternating current		CAUTION: risk of electric shock
	Earth (ground) terminal		CAUTION or WARNING: Refer to instrument documentation
	Protective conductor terminal		Fuse
	Frame or chassis ground		

FIGURE 1-2 Safety symbols

Chapter 2: Magnet System Design, Installation, and Operation

2.1 General

This chapter provides the user insight into the design, installation, and operation of a typical electromagnet. For information on how to install the Model 648 please refer to Chapter 3. For Model 648 operation information, refer to Chapter 4.

2.2 Major Components of the Magnet

A magnet used with the Model 648 electromagnet power supply typically has an iron pole, twin coil, 7 in or 10 in pole diameter, variable air gap, and is water cooled. Larger magnets can be used depending on their electrical parameters and the magnetic field requirements. The electromagnet provides a uniform magnetic field in the air gap between two adjustable poles. The samples, which are to be tested for their magnetic properties, are placed in the air gap with appropriate monitoring equipment attached. By varying the polarity and intensity of the field, useful data can be collected. A typical electromagnet is shown in FIGURE 2-1.

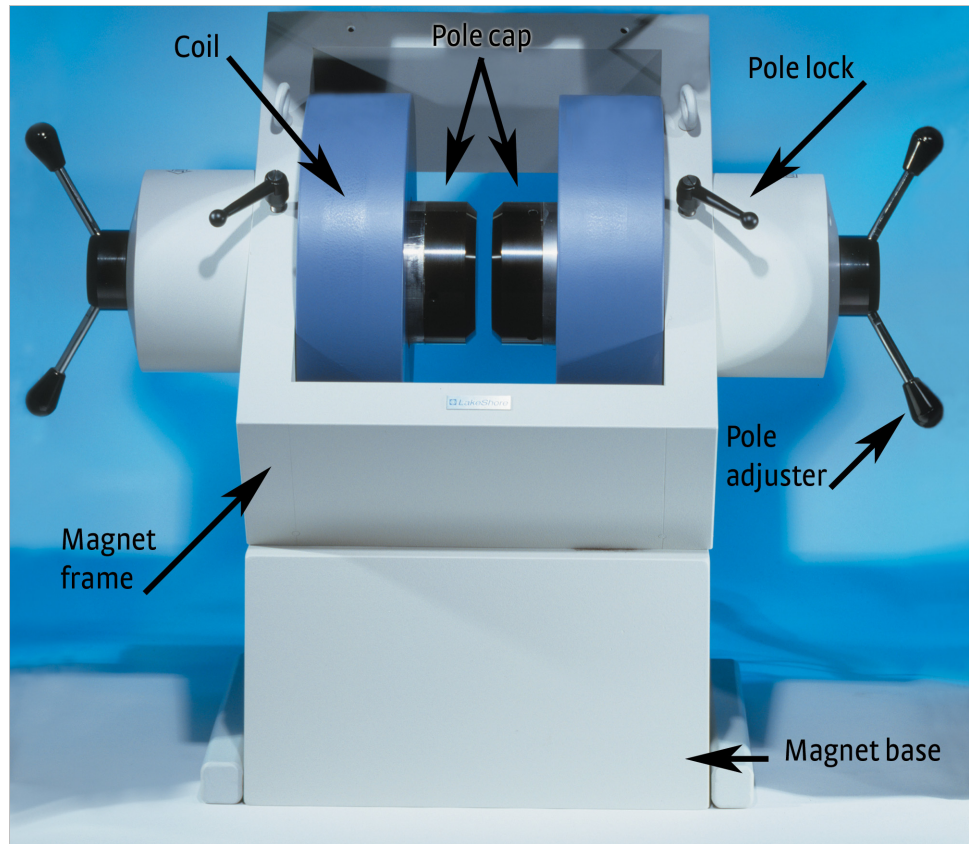

FIGURE 2-1 A typical electromagnet

2.3 Magnet Construction

The magnet consists of two water-cooled coils surrounding adjustable iron poles, which are fitted into an iron frame. The frame supports the poles and coils, and improves the magnet's efficiency. The iron poles are fitted with adjusting mechanisms so that the air gap width can be set. Lock mechanisms are provided to hold the poles in place after adjustment is made. The poles faces have pole caps attached, which provide the desired magnetic focus. The size and shape of the pole caps are chosen according to the size of the sample being tested and the magnetic field requirement.

2.4 Connecting the Magnet

Connecting the magnet to the power supply requires three separate circuits: the cooling water hoses, the main high current power lines, and the safety switches. These may include any combination of temperature and flow switches. These connections are shown in FIGURE 2-2.

2.4.1 Water Hose Connection

Water-cooling is essential for these magnets. The power dissipated can raise the temperature of the coils to the point where they will be destroyed. In addition, the samples being tested may exhibit changes in their magnetic performance with changes in temperature causing errors in the collected data. Typical water connection is shown in FIGURE 2-2. The magnets may be supplied with hose barbs or standard hose fittings. The coils are connected in parallel so that the water temperature rise is the same for both. Every effort should be made to insure that the flow rate in both coils is the same. The minimum flow required is usually specified by the magnet vendor.

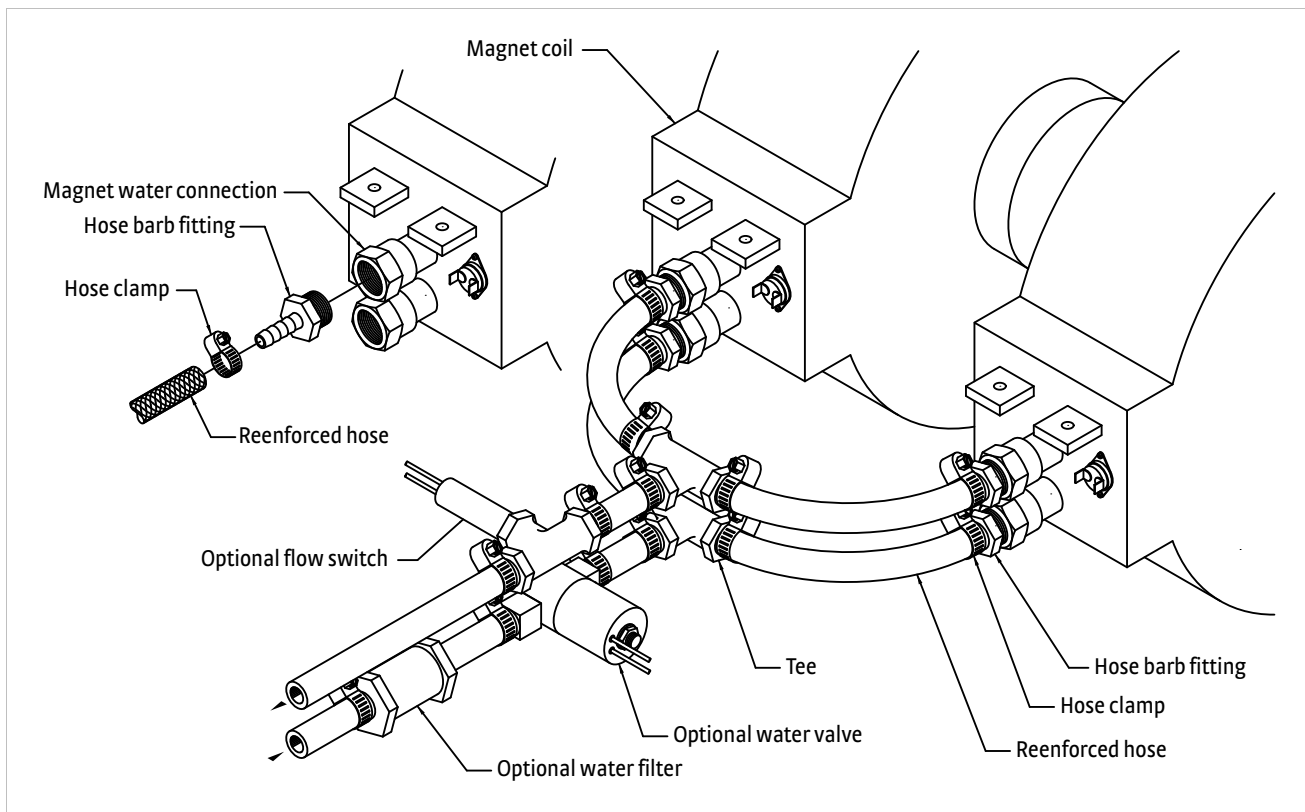

FIGURE 2-2 Typical magnet water hook-up

2.4.2 Magnet Coil Wiring

Typical magnet coil wiring is shown in FIGURE 2-3. The connecting cable used should be of sufficient gage to prevent excessive voltage drop and heat rise in the cable. The cables should be as short as possible to minimize the voltage drop. Current carrying capacities for various sizes of cables and cable lengths are shown in TABLE 3-3. The connections must be made with the correct size of hardware for the magnet terminal. We recommend the use of a spring or Belleville washer for cable terminations. When the parts of a connection expand and contract with changes in temperature, they tend to loosen. A spring washer will reduce this tendency.

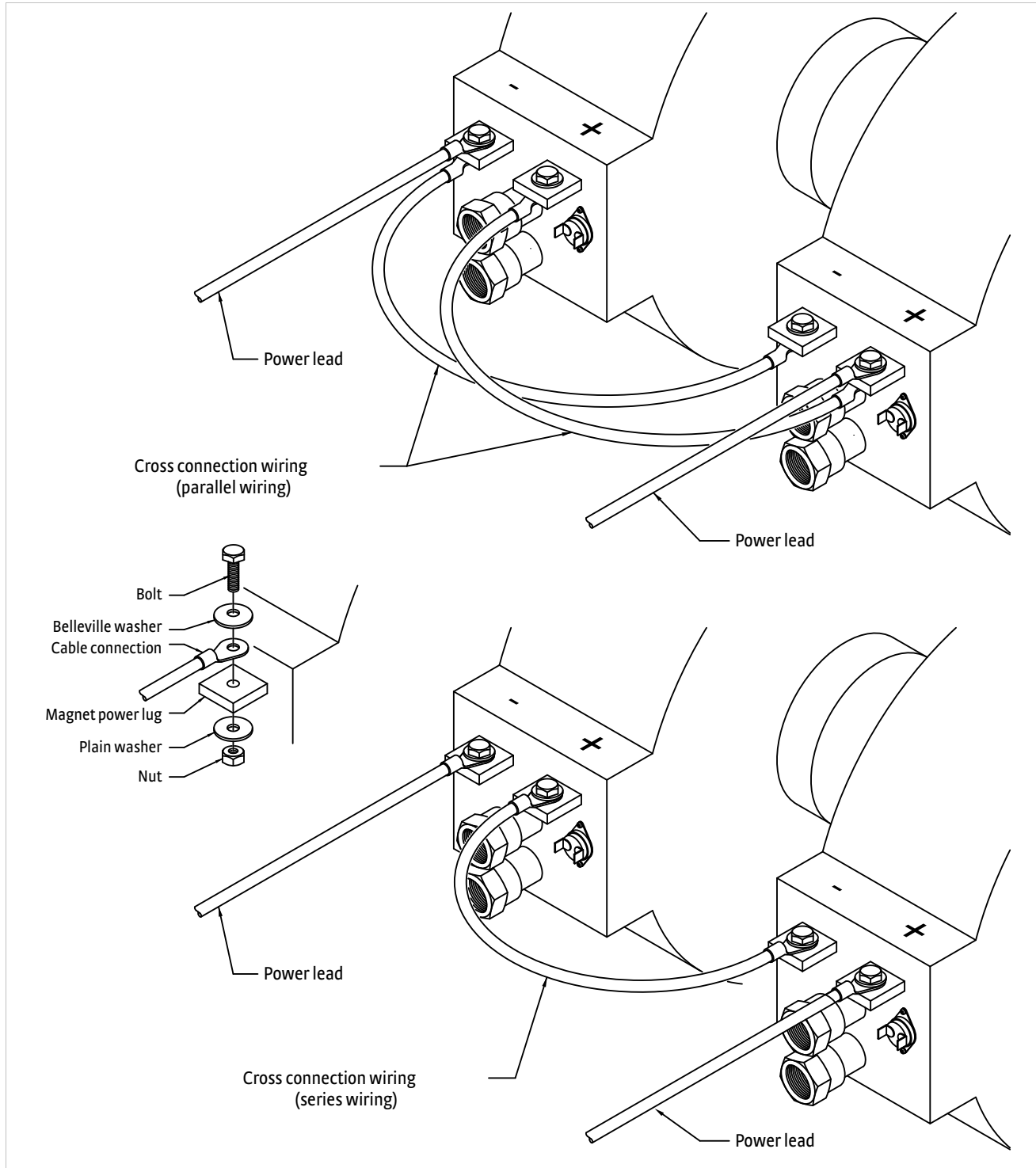

FIGURE 2-3 Typical magnet coil wiring showing series and parallel connections

2.4.3 Temperature Switches and Flow Switches

As discussed in section 2.4.1, water-cooling for the magnet is essential. To protect the magnet from damage resulting from an interruption in cooling water, a flow switch, temperature switches, or both should be installed. The switches must have a normally open contact (switch is open when no water is flowing), and if switches are used, they must be connected in series. The switches are then connected to the flow switch terminals of the magnet connector on the Model 648. The Model 648 monitors the switches and if an open is detected, the output current is ramped to zero. (Flow switch monitoring depends on water valve mode setting. See section 4.13 and section 4.14 for details.) Given the cost of the magnet, it is prudent to use both temperature and flow switches. Some installations use two flow switches, one in the exhaust line of each coil so that if a clog occurs in only one coil, it can be detected. FIGURE 2-4 shows the typical flow and temperature switch connection.

! CAUTION

Care must be used in the selection of the flow switch. Some switches use a sensitive reed switch, which can be overpowered by stray flux from the magnet and will not open when the magnet is operating at high field. The flow switch must be tested by turning off the water while the magnet is operating at full current.

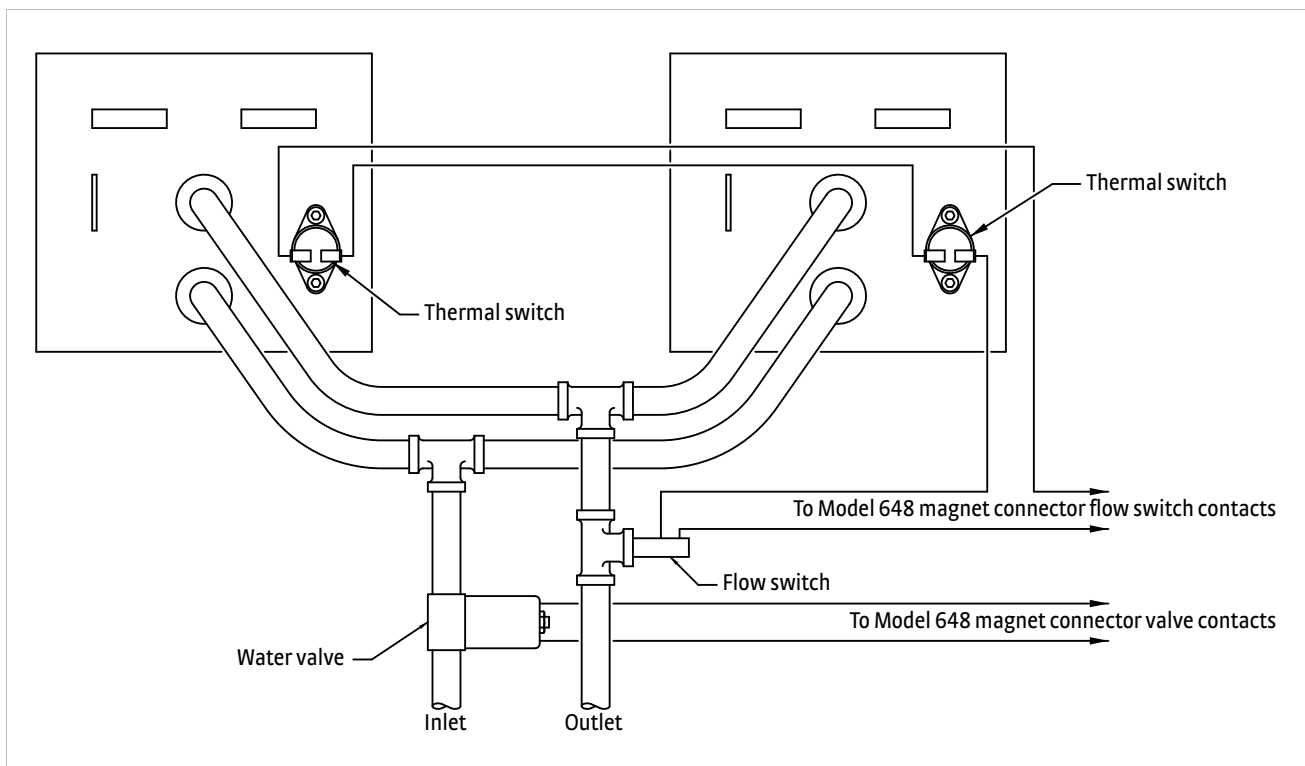

FIGURE 2-4 Typical thermal switch, flow switch and valve wiring

2.4.4 Cooling Water and Water Valve

The cooling water for the magnet can be drawn from the municipal water facility or from a dedicated re-circulating water chiller designed for this purpose. When water is drawn from the municipal water facility, the water should be turned on only when it is required to reduce consumption and reduce the likelihood of scale build-up and condensation in the magnet. The water can be turned on and off manually when the magnet is used, or automatically with a solenoid valve. The Model 648 provides automatic control and a 24 VAC at 1 A output for this purpose. The optional water valve is shown in FIGURE 2-2. The water inlet line should also be fitted with a sediment filter (not shown) to reduce scale build-up in the magnet coils and connecting lines.

2.4.5 Grounding

A ground connection (tapped hole) is usually available at the rear of the electromagnet frame. This ground point is provided for customers who would like to use the electromagnet frame as a signal ground or will be bringing hazardous live voltages near the electromagnet and would like to make it an electrical safety ground. Please verify suitability for such a function and compatibility with local and national electrical codes before making ground connections. Scrape off excess paint near the connecting screw to ensure a good electrical contact with the bare steel of the electromagnet frame.

2.4.6 Final Check-Out

When all of the connections have been made, the system should be tested to be sure it is operating correctly. The settings for the magnet water should be checked to verify that they are correct for the configuration which has been installed (section 4.13). The maximum current setting for the magnet should be set also (section 2.5.2 and section 4.12.1).

2.5 Electromagnet Operation

This section provides a brief description of the typical operation of an electromagnet. For operation of the Model 648, refer to Chapter 4.

2.5.1 Air Gap and Pole Caps

The first step in setting up a magnet for operation is to select the proper pole caps and adjust the air gap. These parameters are determined by the size and shape of the sample, and the connections that must be made to the sample. Generally, a smaller pole face provides a higher field within the air gap. A smaller air gap also provides a higher field. The pole faces must be selected to accommodate the size of the sample being tested. The air gap is selected based on the size of the sample and the other equipment being used. The curves for field versus current for various air gaps and pole cap sizes for the Lake Shore Model EM7-HVA are shown in FIGURE 2-6 through FIGURE 2-7. It also shows that these parameters are not linear. This must be taken into account when operating an electromagnet. To obtain linearity, it is necessary to operate the magnet and power supply under field control (section 2.5.3).

2.5.2 Maximum Current and Power

The Model 648 was designed to operate with a magnet load resistance of 0.50 Ω , but will provide full current output within a resistance range of 0.41 Ω to 0.55 Ω . The Model 648 will also work outside of the previously mentioned resistance range, but will be limited by two factors: internal power dissipation and compliance voltage. FIGURE 2-5 plots the maximum current output versus a resistance range of 0.00 Ω to 1.00 Ω .

Also to be taken into account, the resistance of a magnet will rise with a rise in temperature. The power dissipated in the magnet is given by: $P = I^2R$. If the current remains constant, the power dissipated will rise proportionately with the rise in resistance.

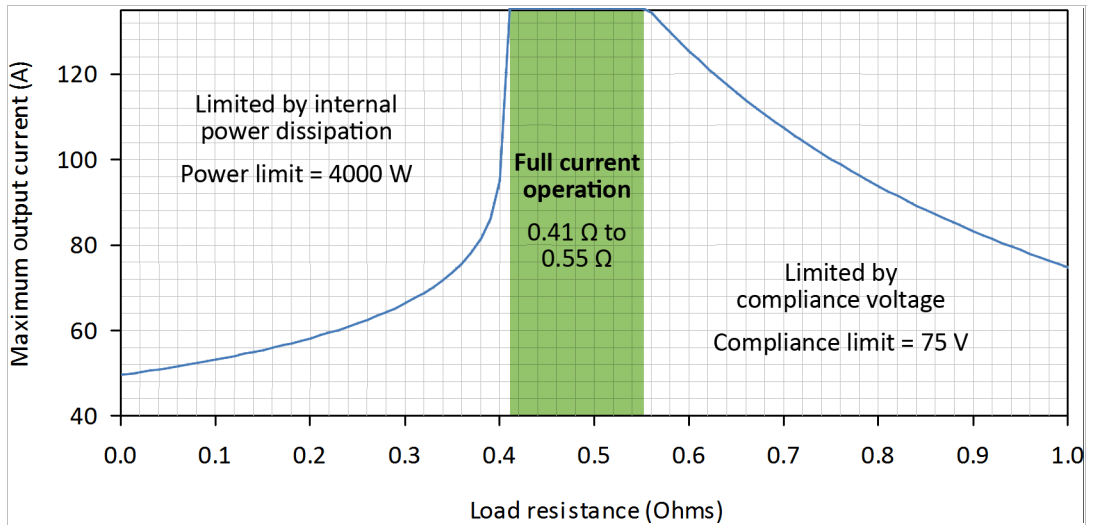

FIGURE 2-5 Maximum current output vs. resistance

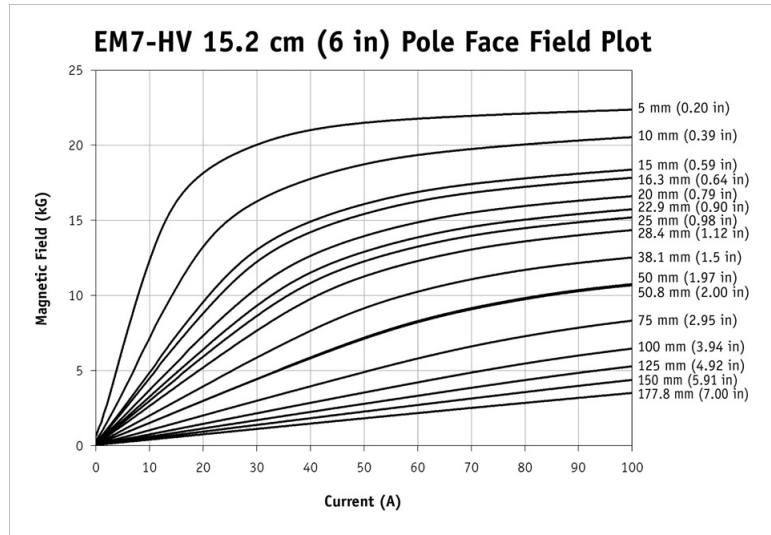

FIGURE 2-6 Typical curves of field vs. current for 6 inch pole face on the EM7

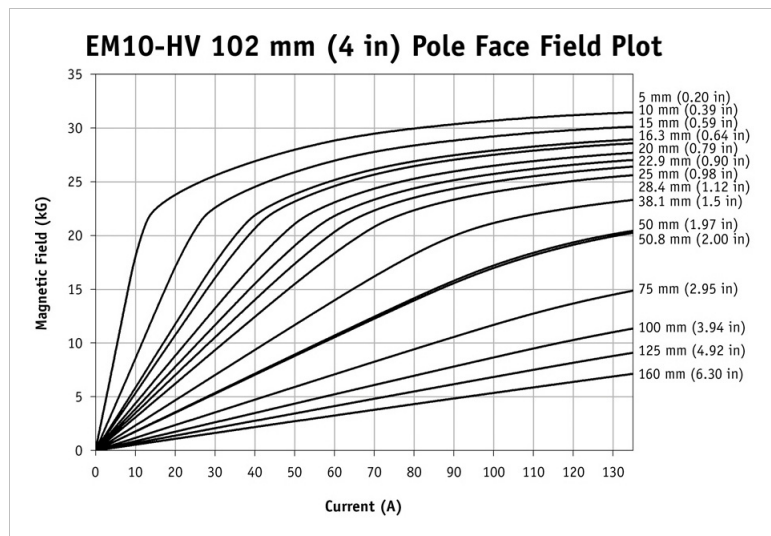

FIGURE 2-7 Typical curves of field vs. current for 4 inch pole face on the EM10

2.5.3 Operation Under Field Control

To obtain a linear field ramp, a magnetic sensor such as a Hall probe is placed in the air gap along with the sample being tested. The sensor is connected to a gaussmeter. The output of the gaussmeter is used to correct the programming input to the power supply. In this way non-linearity can be corrected. Lakeshore manufactures probes and gaussmeters for this purpose.

2.5.4 Avoiding Cooling Water Condensation

If the temperature of the cooling water is too cool relative to the air temperature and humidity, condensation can occur. Condensation inside the power supply can cause severe damage. To avoid condensation, the power supply operator must remain cognizant of the ambient air temperature, cooling water temperature, and the relative humidity. Lake Shore defines the limits of these conditions as follows:

- ambient temperature = 18 - 28 °C (64 - 82 °F)
- cooling water temperature = 15 - 25 °C (59 - 77 °F)
- humidity = 20 - 80% (non-condensing).

Knowing the actual state of these conditions, the operator can calculate the dew point, or temperature at which condensation will occur. TABLE 2-1 and TABLE 2-2 are included to aid in dew point calculation.

		% Relative Humidity																	
°C	100	95	90	85	80	75	70	65	60	55	50	45	40	35	30	25	20	15	10
32	32	31	31	29	28	27	26	24	23	22	20	18	17	15	12	9	6	2	0
29	29	28	27	27	26	24	23	22	21	19	18	16	14	12	10	7	3	0	—
27	27	26	25	24	23	22	21	19	18	17	15	13	12	10	7	4	2	0	—
24	24	23	22	21	20	19	18	17	16	14	13	11	9	7	5	2	0	—	—
21	21	20	19	18	17	16	15	14	13	12	10	8	7	4	3	0	—	—	—
18	18	17	17	16	15	14	13	12	10	9	7	6	4	2	0	—	—	—	—
16	16	14	14	13	12	11	10	9	7	6	5	3	2	0	—	—	—	—	—

TABLE 2-1 Dew point calculation (in degrees Celsius)

		% Relative Humidity																	
°F	100	95	90	85	80	75	70	65	60	55	50	45	40	35	30	25	20	15	10
90	90	88	87	85	83	81	79	76	74	71	68	65	52	59	54	49	43	36	32
85	85	83	81	80	78	76	74	72	69	67	64	61	58	54	50	45	38	32	—
80	80	78	77	75	73	71	69	67	65	62	59	56	53	50	45	40	35	32	—
75	75	73	72	70	68	66	64	62	60	58	55	52	49	45	41	36	32	—	—
70	70	68	67	65	63	61	59	57	55	53	50	47	44	40	37	32	—	—	—
65	65	63	62	60	59	57	55	53	50	48	45	42	40	36	32	—	—	—	—
60	60	58	57	55	53	52	50	48	45	43	41	38	35	32	—	—	—	—	—

TABLE 2-2 Dew point calculation (in degrees Fahrenheit)

Example: Determine the actual air temperature and relative humidity. Find the closest air temperature in the left-hand column and the closest relative humidity across the top. If the air temperature is 24 °C (75 °F) and the relative humidity is 35%, the intersection of the two shows a dew point of 7 °C (45 °F). Therefore, for the given conditions, the cooling water must remain above 7 °C (45 °F) to prevent condensation.

Chapter 3: Installation

3.1 General

This chapter provides general installation instructions for the Model 648 electromagnet power supply.

CAUTION

To ensure the best possible performance and maintain operator safety, read this entire chapter before installing the instrument and applying power. Serious hazards can exist when an instrument of this power capacity is used incorrectly. If you do not understand any section of this manual, consult Lake Shore for clarification. Lake Shore Cryotronics, Inc. assumes no responsibility for damage or injuries incurred due to improper installation, defeat of any of the safety features, or misuse of this power supply.

3.2 Inspection and Unpacking

Inspect shipping containers for external damage before opening them. Photograph any container that has significant damage before opening it. If there is visible damage to the contents of the container, contact the shipping company and Lake Shore immediately, preferably within five days of receipt of goods. Keep all damaged shipping materials and contents until instructed to either return or discard them.

Open the shipping container and keep the container and shipping materials until all contents have been accounted for. Check off each item on the packing list as it is unpacked. Instruments themselves may be shipped as several parts. The items included with the Model 648 are described in the following list. Contact Lake Shore immediately if there is a shortage of parts or accessories. Lake Shore is not responsible for any missing items if not notified within 60 days of shipment.

Inspect all items for both visible and hidden damage that occurred during shipment. If damage is found, contact Lake Shore immediately for instructions on how to file a proper insurance claim. Lake Shore products are insured against damage during shipment, but a timely claim must be filed before Lake Shore will take further action. Procedures vary slightly with shipping companies. Keep all shipping materials and damaged contents until instructed to either return or discard them.

If the instrument must be returned for recalibration, replacement or repair, a returned goods authorization (RA) number must be obtained from a factory representative prior to return. The Lake Shore RMA procedure is in section 6.12.2.

Items Included with the Model 648 electromagnet power supply:

- 1 Model 648 instrument
- 1 Model 648 user's manual
- 1 analog I/O mating connector
- 1 set of output terminal fasteners
- 1 wiring cover plate and screws (shipped attached)
- 1 2-pin detachable terminal block
- 2 4-pin detachable terminal blocks
- 1 8-pin detachable terminal block
- 2 hose clamps
- 1 output lug cover and screws
- Flow switch (shipped attached)
- 1 water hose cover (shipped attached)
- 1 4 mm hex key
- 1 power cable strain relief assembly
- 1 floor mounting kit

3.2.1 Moving and Handling

Casters are installed on the base to allow the unit to be rolled around. Four lifting lugs are provided for ease of moving and handling the Model 648. Always use all four lifting lugs when lifting the unit. Because of its weight, the Model 648 should be handled by mechanical means.



To avoid injury to personnel, always observe proper lifting techniques in accordance with OSHA and other regulatory agencies.

3.3 Rear Panel Definition

This section defines the rear panel of the Model 648. Rear panel information is summarized in TABLE 3-1. For each feature, refer to the corresponding sections that contain installation instructions and connector pin-outs.



Verify that the Model 648 has been set up for the proper line voltages.



Make rear panel connections with the instrument power off.

Voltage selection	28 DIN terminals are provided behind a wiring cover to facilitate setting the correct input voltage	section 3.4.1
Circuit breaker	An adjustable current auto-resetting circuit breaker is provided behind a wiring cover to protect main power circuits	section 3.4.2
Fuses	2A class CC fuses (2) are provided behind a wiring cover to protect the start-up circuit	section 3.4.3
Cable entry	A 38 mm (1.5 in) hole is provided for power cable entry and strain relief bushing	section 3.4.4
Power terminals	Four DIN terminals are provided behind a wiring cover for connection of power wiring	section 3.4.5
Magnet connector	A 4-pin detachable screw terminal block is provided to connect the optional magnet water valve power and temperature and/or flow switch	section 3.5
Auxiliary connector	An 8-pin detachable screw terminal block is provided to connect the optional emergency stop, remote fault indicator, remote enable and chassis ground	section 3.6
Power supply connector	One 2-pin detachable screw terminal block is provided to connect the optional power supply water valve power	section 3.7
Cooling water	Two 12.7mm (1/2 in) hose barbs are provided for input and output of cooling water	section 3.8
Output terminals	Two output lugs are provided for the magnet cable connections;	section 3.9
Analog I/O	A 15-pin D subminiature connector provides output for current and voltage monitoring, as well as analog programming input.	section 3.10
USB	A B-type USB connector that emulates a standard RS-232C serial port is provided for use with the USB computer interface.	section 3.11.1 and section 5.3.3
IEEE-488 interface	An IEEE-488 compliant interface connector is provided for use with IEEE-488 parallel computer interface.	section 6.3 and section 3.11.2
Chassis connection	An earth ground connection is provided to facilitate connection to the magnet frame if noise problems exist	section 3.12
Flow switch	A 1 gpm flow switch, mandatory for operation	—

TABLE 3-1 Rear panel connector identification

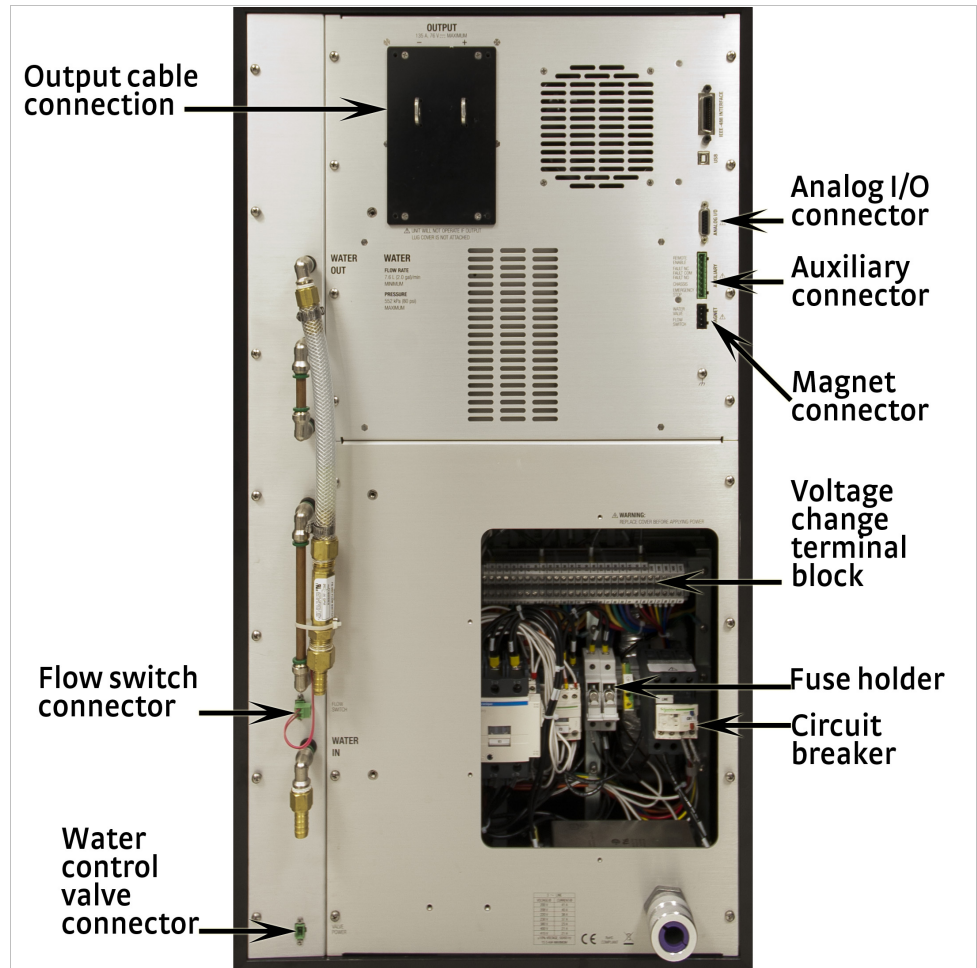

FIGURE 3-1 Model 648 rear panel : Left: Bottom half (shown with wiring cover removed); Right: Top half

3.4 Power Wiring and Setup

This section describes how to connect the Model 648 to the line power. Please follow these instructions carefully to ensure proper operation of the instrument and the safety of operators.

The Model 648 must be permanently wired to the facilities main wiring by a qualified electrician adhering to all local codes and standards.



Do not attempt to connect the power mains using a detachable cord. The power wiring must be permanently wired to the facilities main wiring by a qualified electrician. Failure to comply could result in injury or death to personnel.

3.4.1 Line Voltage Selection

The Model 648 has seven AC line voltage configurations covering seven different input voltages. The nominal voltage and voltage tap setting and the circuit breaker current setting for each configuration is shown in TABLE 3-2. Verify that the unit is configured correctly for the voltage being applied to the unit before applying power.

Voltage tap	Circuit breaker
200 V	50 A
208 V	50 A
220 V	46 A
230 V	46 A
380 V	37 A
400 V	37 A
415 V	37 A

TABLE 3-2 Voltage and current selection

Changing line voltage is accomplished by moving four wires to the required voltage terminals. The required location is shown in FIGURE 3-2. To change the voltage setting, follow these procedures.

1. Loosen the four terminal screws in the voltage-change terminal block to which the wires are connected.
2. Move the wires to the required voltage position.



The wires are held in place in a locator card to maintain their spacing and prevent miswiring.

3. Loosen the screws in the new terminal location four full turns to allow the entry of the wires.
4. Move all four wires at once by lifting the locator card to extract the wires from the terminals.
5. Move the card and wires to the correct location and insert the wires completely so that the card rests against the terminals.
6. While holding the locator card in place to keep the wires fully inserted, tighten the terminal screws. The recommended torque requirement is 0.5 Nm.
7. Tighten the four terminals where the wires were previously.

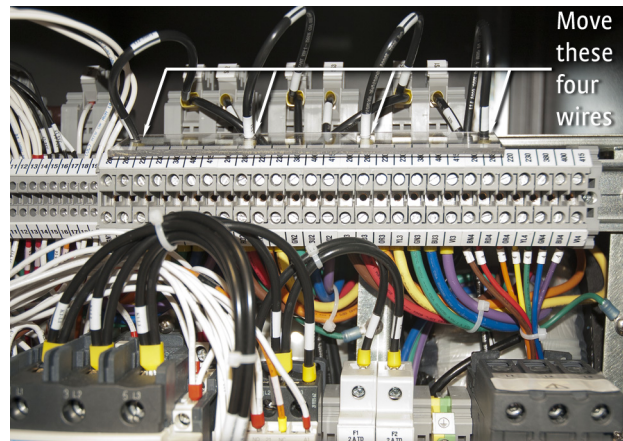

FIGURE 3-2 Voltage change detail

3.4.2 Circuit Breaker Setting

The circuit breaker is an important safety feature of the Model 648. The required current setting depends on the voltage for which the unit is wired (refer to TABLE 3-2 for the correct setting). Verify that the circuit breaker is set correctly for the line voltage being applied to the unit. To set the breaker trip current, open the access cover on the circuit breaker and adjust the current setting dial to the correct value (FIGURE 3-3).



The circuit breaker has an automatic reset feature. If the breaker trips, it will reset within a few minutes and the unit can be restarted. If the unit trips again after a short time, the trip current may be set incorrectly.

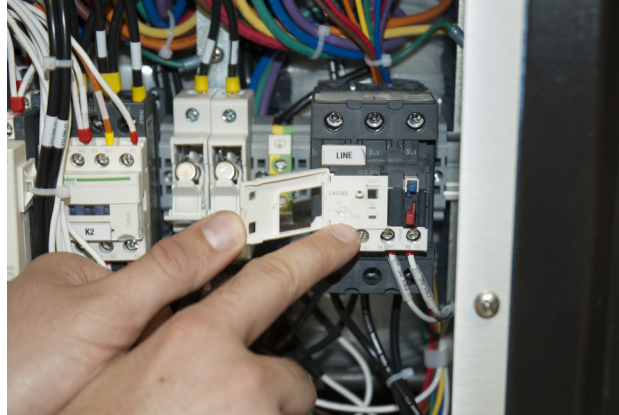

FIGURE 3-3 Circuit breaker

3.4.3 Start-up Fuses

The start-up transformer and associated circuitry are energized whenever the power is connected. To protect this circuitry, two 2 A, class CC time-delay fuses are provided. A fuse is accessed by pulling open the access door on the fuse holder. The fuses are inserted small-end first as shown in FIGURE 3-4.

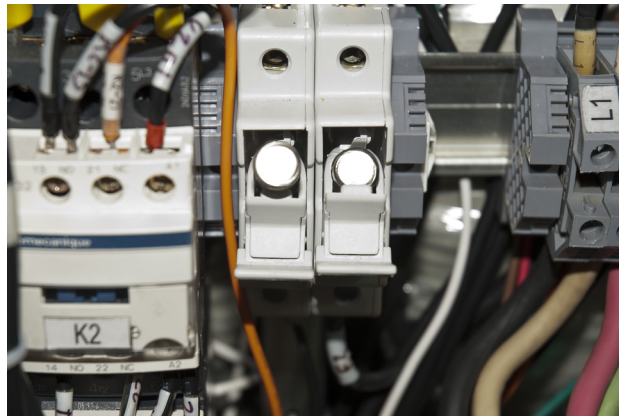

FIGURE 3-4 Fuses being inserted into the fuse holder:

3.4.4 Cable Entry

A 38 mm (1.5 in) diameter hole is provided for the power wiring to enter the unit. Wiring must be approved by your local electrical product safety agency and be sized appropriately to accommodate both the configured working voltage and maximum current draw. A strain relief bushing must be used in installation. Two different compression grommets and slip washers are provided. The first, a yellow slip washer and its corresponding grommet, are provided in the Model 648 installation kit and are provided assembled inside the bushing body. It will accommodate a 15.9 mm to 19.0 mm (0.63 in to 0.75 in) round neoprene jacketed cable. The second, a purple slip washer and its corresponding grommet, are provided in the Model 648 installation kit as well, bagged separately from the bushing body. It will accommodate a 19.0 mm to 22.2 mm (0.75 in to 0.88 in) round neoprene jacketed cable. If either of the bushings provided will not work with your cable, a strain relief of the appropriate type and size must be provided by the installing agency.

To ensure proper operation of the strain relief bushing, it must be tightened to a torque of 68 Nm (50 ft/lbs). A typical cable entry with bushing is shown in FIGURE 3-5.

CAUTION

Failure to install a strain-relief bushing is a hazard and could cause injury or death to the operating personnel in the event of a fault. Lake Shore reserves the right to void the warranty of any instrument not properly installed.

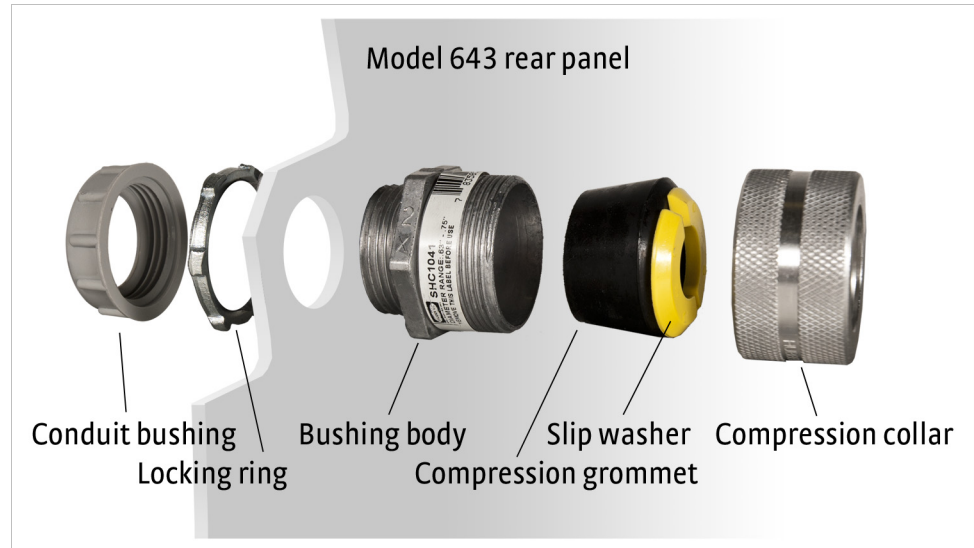

FIGURE 3-5 Typical cable entry with bushing

3.4.5 Power Input Terminals



The Model 648 requires a 4 conductor power cable (non-detachable). The input to the Model 648 is wired in a delta configuration, but will operate from a delta or wye source. If operating from a wye source, the neutral line (N) is not used.

The ground (the green/yellow ground terminal) connects the instrument chassis to the electrical ground (safety ground), and is required to prevent fault conditions which may be hazardous to operating personnel. In no case should the safety ground line be omitted. In no case should a neutral line be used as a safety ground.

All wiring must comply with the code requirements of the locality in which the instrument is installed. FIGURE 3-6 shows typical input wiring. The wire ferrules shown are not required, but are recommended to prevent stray strands from shorting to adjacent terminals. For safety, the ground wire must be longer than the phase conductors, as shown in FIGURE 3-6

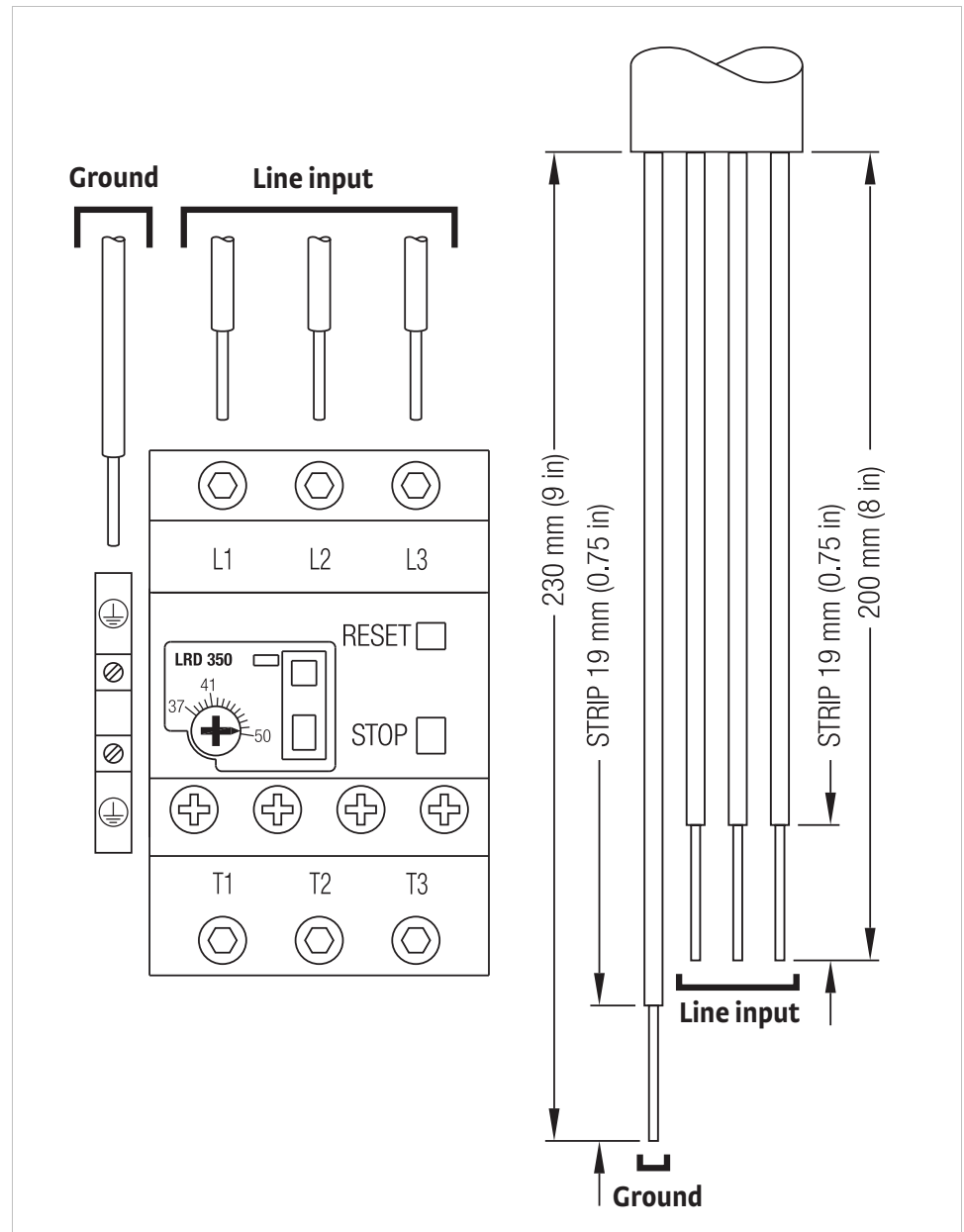

FIGURE 3-6 Typical input wiring

3.4.6 Wiring Cover

When the power wiring, voltage setting and current setting are complete, install the wiring cover with the four 6-32 × 3/8, and the two 10-32 × 5/8 screws provided. The wiring cover installation is shown in FIGURE 3-7.



Do not connect power or attempt to operate the unit with this cover removed. Lethal voltage and currents exist inside. There is a risk of injury or death if an operator or technician comes in contact with these potentials.

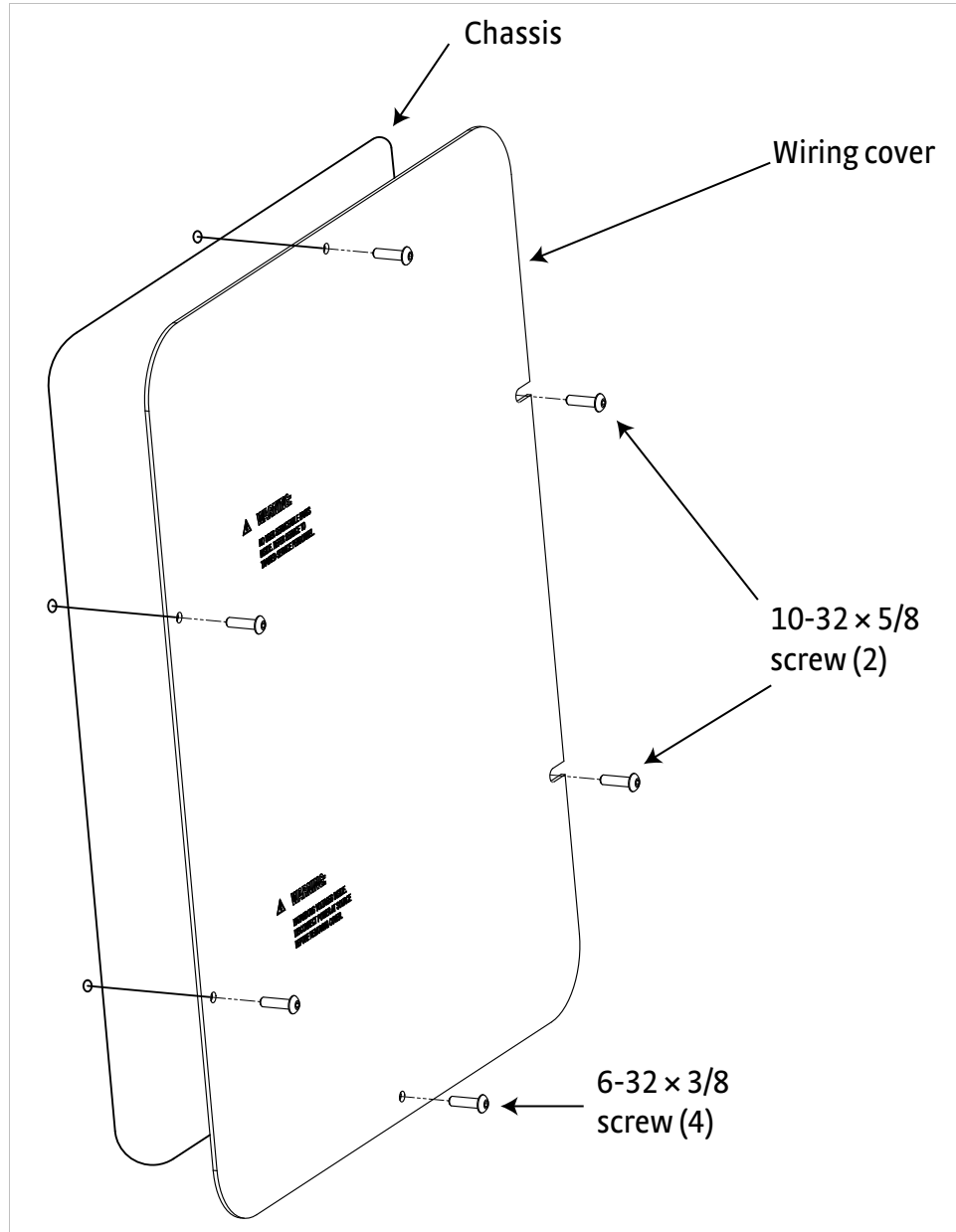

FIGURE 3-7 Wiring cover installation

3.4.7 Mains Wiring

No wiring is provided with the unit. In all cases, the field connection of the mains wiring must comply with all local wiring codes where the Model 648 is installed. The power source must be protected with a dedicated circuit breaker or fuse. The rating of the protection device must be a value equal to that of the internal breaker setting or the next higher commercially available value (TABLE 3-2). Wiring must be provided with a minimum sizing requirement of 6 AWG (13 mm²). A disconnect switch must be installed within 3 meters (10 ft) of the Model 648, marked clearly in layman's language, and easily accessible. Ensure the unit is positioned to allow for easy access to the disconnect switch.



Do not attempt to connect the power mains using a detachable cord. The power wiring must be permanently wired to the facilities main wiring by a qualified electrician. Failure to comply could result in injury or death to personnel.

3.5 Magnet Connector

The magnet connector provides terminals for an optional magnet temperature switch or magnet water flow switch and an optional magnet water control solenoid valve. The flow or temperature switch must have a normally closed contact rated at 5 V at 10 mA. A contact closure is required to enable the Model 648 output. If a switch is not used, a jumper is required. To operate a solenoid water valve for the magnet, 24 VAC at 1 A is provided. This output is controlled by the power supply, either automatically via software, or manually through the magnet water menu.

Water control is desirable to reduce water consumption when the water comes from a municipal facility. Turning the water off when it is not required also reduces the probability of condensation on the magnet or connecting hoses. If the cooling water comes from a facility chiller system, condensation is not usually a problem and a control valve is not required. In this case, it is appropriate to install a flow switch (optional) or temperature switch (optional) to monitor the water flow and protect the magnet in the event of a water flow interruption. FIGURE 3-8 shows examples of typical magnet connector wiring.

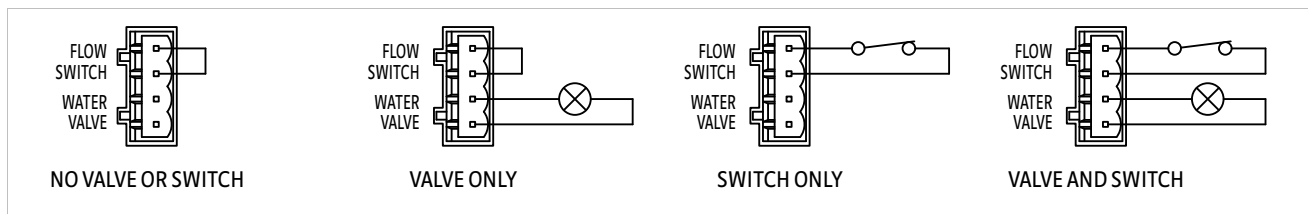

FIGURE 3-8 Typical magnet connector wiring

3.6 Auxiliary Connector

The auxiliary connector provides terminals for an emergency stop, contacts for a remote alarm, remote enable and a chassis connection. The emergency stop must have a normally closed contact rated at 24 V at 1 A. When the contact is opened, it turns off the Model 648. If an emergency stop switch is not used, a jumper is required. A normally closed or normally open contact is provided to control a remote alarm annunciator. This set of contacts is rated at 30 V, 1 A. If it is desirable to have a remotely located alarm to echo the internal alarm, these contacts can be used with an external power source and external alarm. The remote enable switch must have a normally closed contact rated at 5 V at 10 mA. Contact closure is required to enable the Model 648 output. If a remote enable switch is not used, a jumper is required. FIGURE 3-8 shows some typical auxiliary connector wiring. A chassis terminal is provided in the event that any of the wires require a shield to minimize noise.

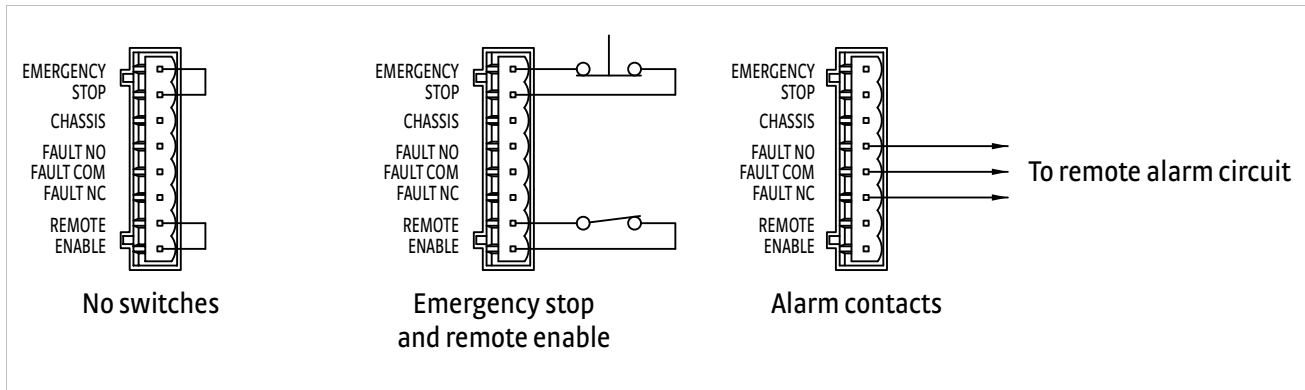

FIGURE 3-9 Typical auxiliary connector wiring

3.7 Power Supply Connector

The power supply connectors provide terminals for a mandatory water flow switch and an optional cooling water control solenoid valve. The flow switch must have a normally closed contact rated at 5 V at 10 mA. Contact closure is required to enable the Model 648 output. To operate a water control solenoid valve for the power supply cooling water, 24 VAC at 1 A is provided. This output is controlled by the power supply, either automatically via software, or manually through the internal water menu.

Water control is desirable to reduce water consumption when the water comes from a municipal facility. Turning the water off when it is not required also reduces the probability of condensation within the power supply and connecting tubing. If the cooling water comes from a facility chiller system, condensation is not usually a problem and a control valve is not required. FIGURE 3-10 shows some typical power supply connector wiring.

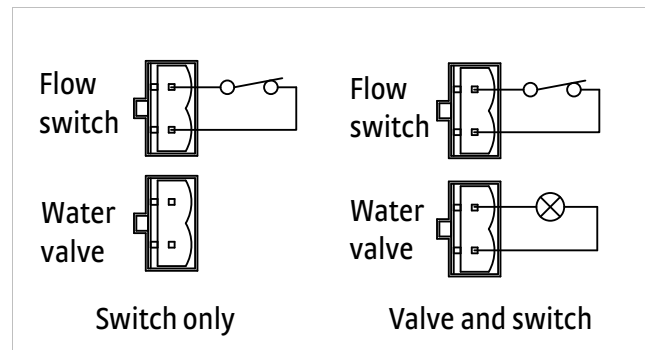

FIGURE 3-10 Typical power supply connector wiring

3.8 Cooling Water

Two 12.7 mm (0.5 in) hose barbs are provided to connect to cooling water. The connection to the cooling water source should be made with two 12.7 mm (0.5 in) I.D. fiberglass reinforced hoses and two 20 mm (25/32 in) adjustable hose clamps. In addition, we recommend the installation of a sediment filter in the input line. A typical water hose connection is shown in FIGURE 3-11.

The cooling water must be clean and free from sediment, salt, and other contaminants, which might clog or erode the water fittings. A minimum flow rate of 7.6 L (2 gal) per minute is required with a maximum pressure of 552 kPa (80 psi). At the 7.6 L (2 gal) per minute flow rate, the Model 648 has a 159 kPa (23 psi) drop across it. When installed, the water valve adds an additional 107 kPa (15.5 psi) drop. The temperature must be kept above 15°C to avoid condensation and below 30°C to ensure adequate system cooling. If water is drawn from a local municipal water source, the optional water valve should be installed for economy and to prevent condensation (section 3.7). If water is supplied by a facility chiller, a valve can still be used but is not required.

CAUTION

Do not use de-ionized water because it is corrosive to the water fittings inside the Model 648.

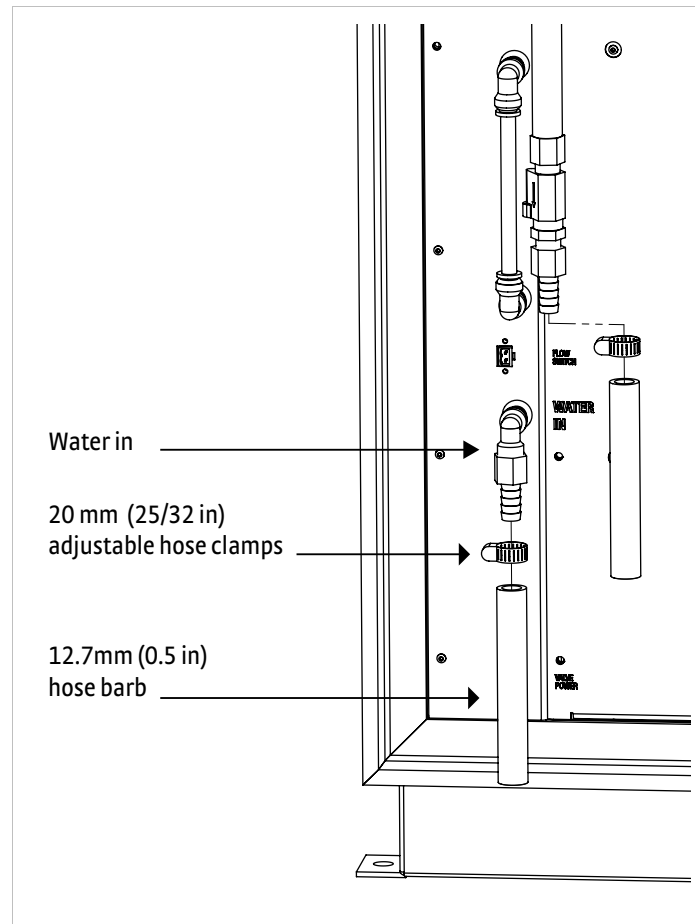

FIGURE 3-11 Typical water hose connection

FIGURE 3-12 shows the connections required when a water valve is used. The optional solenoid water valve is supplied mounted to a bracket which mounts to the rear of the Model 648 as shown in FIGURE 3-12. Hose connections are made as shown in FIGURE 3-11. When you are finished installing the cooling water hose, ensure the hose cover is installed to prevent damage to the flow switch and copper tubing.

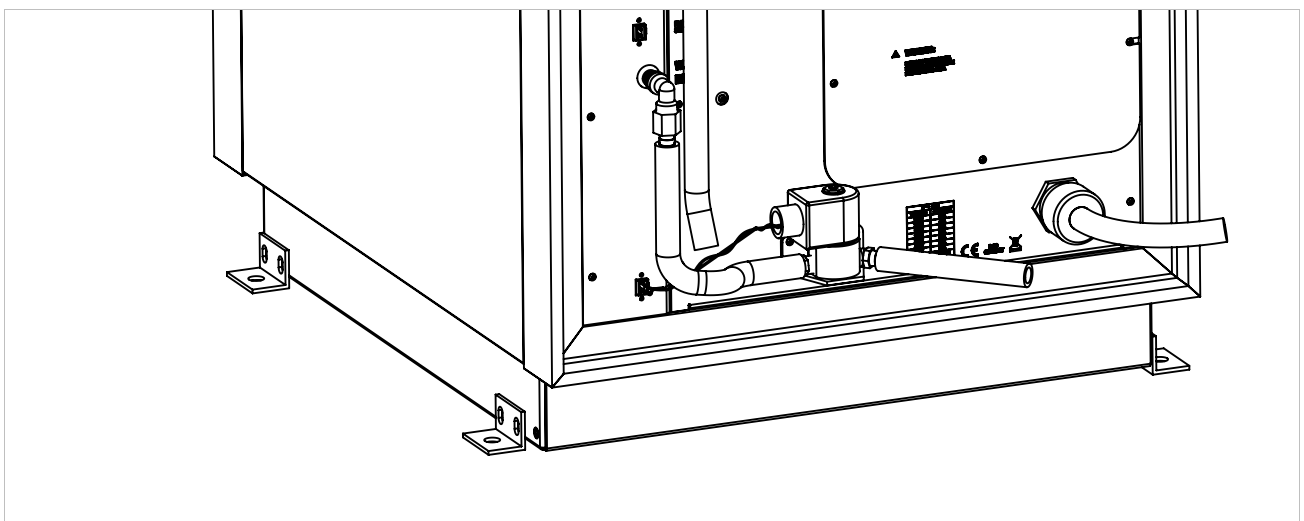

FIGURE 3-12 Water valve connection

3.9 Magnet Cable Connections

Magnet cable connections are made at the OUTPUT + and - terminals on the rear panel. These plated copper bus bars accommodate M8 (5/16 in) mounting hardware. Two M8 bolts, nuts, and Belleville washers are provided. Use load wires heavy enough to limit the voltage drop to less than 0.5 V per lead. This ensures proper regulation and keeps the cables from overheating while carrying the required output current. TABLE 3-3 lists the current capacity and lead lengths for load connections. Lake Shore sells magnet cables in 10 ft and 20 ft lengths. Refer to section 1.11 for ordering accessories.

FIGURE 3-13 shows how the output cables are connected to the Model 648. A plain washer and a spring or Belleville washer are provided. The Belleville washer is required to maintain contact pressure through varying material thickness due to heating. The magnet leads should be dressed straight down to allow the installation of the mandatory protective lug cover. Lug cover installation is shown in FIGURE 3-13.



If the protective lug cover is not installed, the unit will not power up.

AWG	Area (mm ²)	Capacity (A)	Resistivity ohms/1000 feet	Distance to magnet
				Max output of 135 A
0	53.5	245	0.09827	22 M (72 ft)
2	33.6	180	0.1563	14 M (45 ft)
4	21.2	135	0.2485	8.5 M (28 ft)

TABLE 3-3 Current capacity and total lead lengths

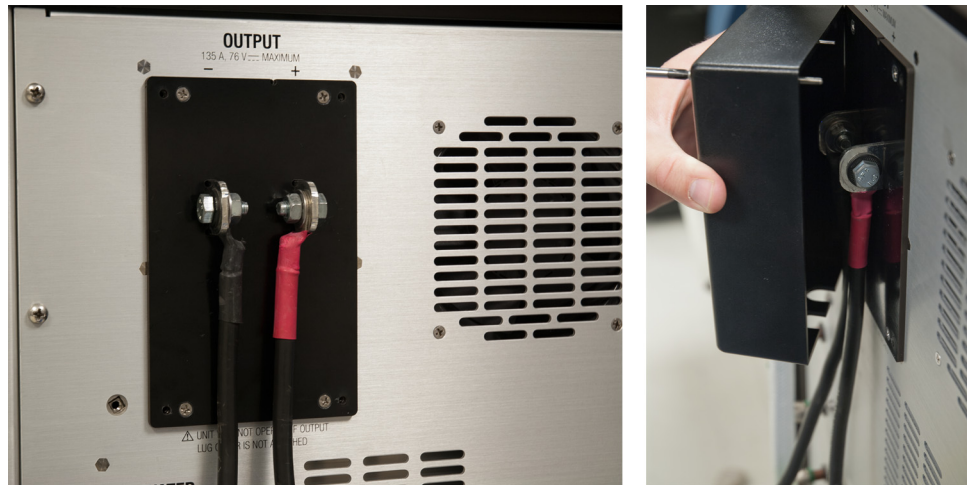

FIGURE 3-13 Output cable connection; Right: Output lug cover installation

3.10 Analog Input/Output Connections

The analog I/O connector provides connections to analog signals used to monitor or control the power supply. A current program input is provided to control the current output. Two outputs are also provided to monitor the output current and the output voltage. The connector and pin-out table is shown in FIGURE 3-14 and TABLE 3-4. Specific information on each function is provided in section 3.10.1 and section 3.10.2.



FIGURE 3-14 Analog I/O connector

Pin	Name	Pin	Name
1	NC	9	NC
2	Chassis	10	Chassis
3	Current program —	11	Current program +
4	Chassis	12	Chassis
5	Voltage monitor —	13	Voltage monitor +
6	Chassis	14	Chassis
7	Current monitor —	15	Current monitor +
8	Chassis		

TABLE 3-4 Model 648 analog/output connector

3.10.1 External Current Programming

The output current can be programmed externally using an AC or DC voltage. This programming voltage can also be summed with the internal current setting or ramp. Refer to section 4.16 to change the external current program mode. The external current programming input is a differential input with a sensitivity of $10\text{ V} = 135\text{ A}$ and an input impedance of $> 50\text{ k}\Omega$. The programming voltage is limited internally to approximately $\pm 10.1\text{ V}$ (category 1) but care must be taken to insure that maximum current capability of the magnet is never exceeded.

3.10.2 Output Current and Voltage Monitors

The output current and output voltage of the power supply can be monitored externally using the monitor output connections on the analog I/O connector. Each output is a buffered, differential, analog voltage representation of the signal being monitored. The current monitor has a sensitivity of $7\text{ V} = 135\text{ A}$ and the voltage monitor has a sensitivity of $7.5\text{ V} = 75\text{ V}$. Both outputs have a $20\ \Omega$ source impedance.

3.11 Computer Interface

The Model 648 can be programmed externally with a computer. Both USB and IEEE-488 ports are provided.

3.11.1 USB Interface Connection

A USB port has been provided to allow remote computer control of the power supply. Refer to Chapter 5, Computer Interface Operation.

3.11.2 IEEE-488 Interface Connection

An IEEE-488 port has been provided to allow remote computer control of the power supply. Refer to Chapter 5, Computer Interface Operation.

3.12 Chassis Connection

A 10-32 screw has been provided for attaching an optional chassis ground connection. This connection is normally not required. However, occasionally there are noise problems associated with a floating magnet or other ancillary equipment.

3.12.1 3-Phase Power Connections

All 3-phase electrical wiring should be completed by a qualified electrician adhering to all local codes and standards, prior to the arrival of a Lake Shore representative for installation and training.

The qualified electrician should refer to the Model 648 electromagnet power supply manual, Chapter 3, to complete the connection of 3-phase power to the Model 648.

If you use a 3-phase water chiller, refer to the Water Chiller manual to complete the connection of 3-phase power to the water chiller.

3.12.2 Attach the Floor Mounting Option

This section briefly outlines the steps necessary to install the floor mounting option. You will need the Model 648 floor mount kit.



Consult with the facilities personnel to confirm that the floor may be modified to support the floor mounting option and to determine the location of water or gas lines that may be present.



There are safety issues concerning the installation of the floor mounting option. These issues can vary depending upon the method and tools you use. These directions are intended only to give a brief summary of the installation process. Consult local codes and regulations before installation.

1. Place the power supply in its designated position.
2. Obtain the four anchoring brackets as shown in FIGURE 3-15.
3. Attach the brackets oriented at 90° angles from the power supply base.
4. Use the hole in each of the bracket as a template, and trace their positions on the floor.

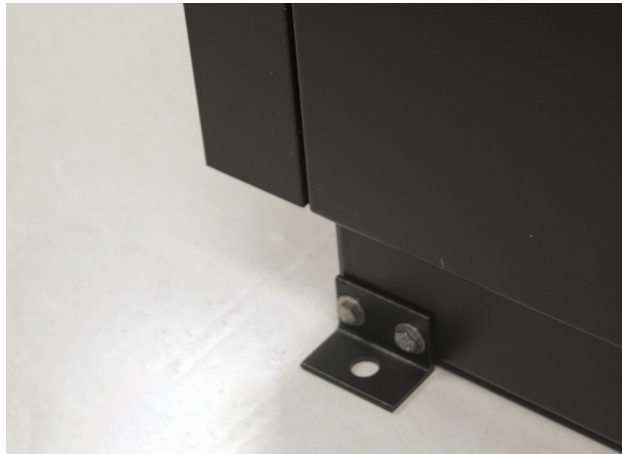

FIGURE 3-15 Floor mount

5. Move the power supply away from its designated position to reveal the traced circles.
6. Using the traced circles as a guide, drill mounting holes in the floor according to local codes and regulations.
7. Move the power supply back to its designated position.
8. Attach securing hardware to fasten the floor mounting straps to the floor.

Chapter 4: Operation

4.1 General

This chapter provides operating instructions for the features of the Model 648 electromagnet power supply. Computer interface instructions are in Chapter 5.

4.1.1 Understanding Menu Navigation

The menu navigation paragraphs provided at the end of each feature is intended to be a quick guide through the necessary key presses to arrive at and set the desired features. See FIGURE 4-1 and TABLE 4-1 for an explanation of the conventions used in the menu navigation.

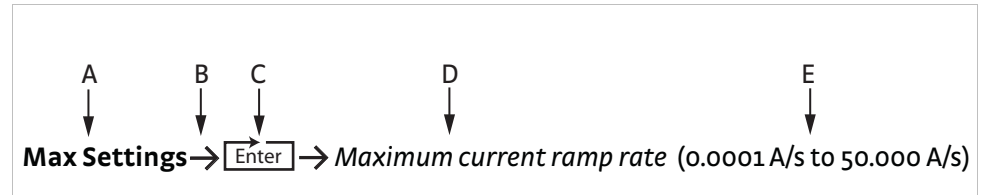

FIGURE 4-1 Menu navigation example

Item	Convention	Explanation
A	Bold	Typically, the first word in the menu navigation is in bold type, which indicates the first key you will need to press.
B	→	The arrow indicates that the screen is advancing to the next screen. In the menu navigation, the item that follows the arrow is the next item you would see on the screen or the next action that you will need to perform.
C		This symbol indicates that you will need to press Enter until you arrive at the desired feature.
D	<i>Italic type</i>	The italic type indicate that there is a setting that needs to be selected.
E	(Parentheses)	The items that follow the italicized word and which are in parentheses, are the available selections to which you can set the desired feature.

TABLE 4-1 Menu navigation key

4.2 Turning Power On

Ensure the unit is configured for the appropriate AC line voltage. The instrument may be damaged if it is turned on with the incorrect voltage selected. Instructions for checking line voltage selection are given in section 3.4.1.



Be sure the unit is connected to an appropriate load before applying power.



The Model 648 will not turn on if an emergency stop switch is not connected or a jumper is not put in its place on the Auxiliary connector at the rear of the unit. The unit will not turn on if it is connected to a voltage source more than 10% greater than the voltage for which it is configured.

The power On and Off buttons are located in the lower right corner of the front panel. Press On to energize the Model 648. The Model 648 can be de-energized by pressing Off, by pressing an optional remote emergency stop button, or by the Model 648 software when a hazardous fault condition is detected. The On and Off buttons are shown in FIGURE 4-2.

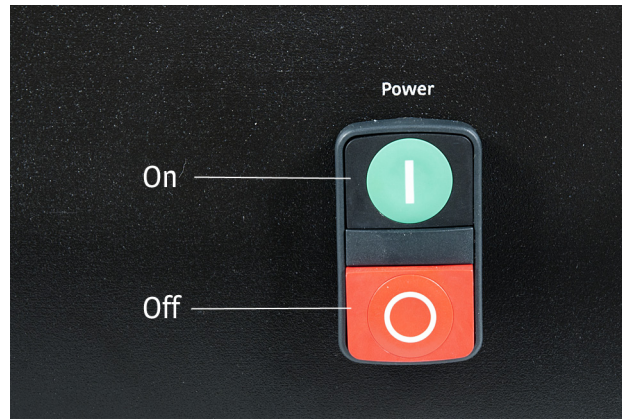

FIGURE 4-2 Model 648 power push buttons

When the Model 648 is turned on, the display shows the Lake Shore logo and the alarm beeper sounds briefly. After a few seconds, a “checking hardware” message will appear in the center of the logo display while the instrument does an internal diagnostic to verify that everything is working. Most of the instrument setup parameter values are retained when power is off with a few exceptions. The output current will always be set to 0 A anytime the instrument is powered up. When the instrument is powered on for the first time, parameter values are set to their defaults, as listed in TABLE 4-4.

When initialization is complete, the instrument will begin its normal reading cycle. Current and voltage readings should appear on the display. Any error messages will appear in the center of the display. Messages listed in TABLE 6-2 are related to the instrument hardware and may require help from Lake Shore service. The messages listed in TABLE 6-3 are related to instrument operation and may be corrected with user intervention. The Model 648 should be allowed to warm up for a minimum of 30 min to achieve rated accuracy.

4.3 Display Definition

The Model 648 has an 8 line by 40 character vacuum fluorescent (VF) display capable of showing both text and graphic images. The features displayed during normal operation include current measurement, voltage measurement, current programming, ramp rate, magnet water status, internal water status, program mode, and internal temperature. Other display configurations appear during parameter setting and data entry operations. These displays are illustrated in their individual operation paragraphs. A typical display is shown in FIGURE 4-3.

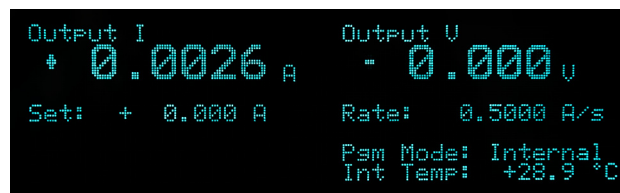

FIGURE 4-3 Model 648 display

4.4 LED Annunciators

There are five LED annunciators on the front panel that are used to indicate the status of the instrument. These provide easy verification of the operation of the instrument. FIGURE 4-4 shows locations of the LEDs.

Fault	On when a hardware fault condition exists; blinking when a soft fault condition exists
Compliance	On when the maximum compliance voltage is reached
Power limit	On when the power in internal devices reaches the maximum limit
Ramping	On when the output current is ramping; blinking when ramp is paused
Remote	On when the instrument is in remote computer interface mode

TABLE 4-2 Model 648 LED descriptions

- 4.4.1 Fault LED** The fault LED lights when an error condition is encountered. It may also be accompanied by an alarm depending on the fault (TABLE 6-2 and TABLE 6-3 defines hardware and operational errors).
- 4.4.2 Compliance LED** The compliance LED lights when the maximum output voltage is reached. This can happen when attempting to rapidly ramp a magnet with higher than usual voltage required to overcome the magnet's inductance. The LED will go out when the condition clears.
- 4.4.3 Power Limit LED** The Model 648 has a hardware power limit to protect the internal power MOSFETs. If the power supply is driving a load which has a resistance lower than the supply's rated minimum, the power required may be higher than the devices can safely handle. If this happens, the power in the devices is prevented from exceeding the safe limit and the power limit LED will light to alert the operator to the condition. The LED will go out when the condition clears.
- 4.4.4 Ramping LED** The ramping LED lights when the internal control circuitry is changing the output current. When the ramp is completed and the current is at the desired point, the LED goes out. The LED does not light when the output current is being controlled by an external source.
- 4.4.5 Remote LED** The remote LED lights when the remote key has been pressed to accept remote computer programming input, or upon receiving the first command over the IEEE bus. When the LED is lit, the main keypad is locked out. Pressing the Local key will return the unit to the local mode and reestablish keypad functions.

4.5 Keypad Definition

The Model 648 has 20 keys separated into three groups on the instrument front panel. The sixteen keys in the center of the grouping combines instrument setup and data entry. The keys to the left control the output current and ramping. The keys to the right assist with menu navigation. See FIGURE 4-4 for key locations. Refer to TABLE 4-3 for keypad descriptions.



FIGURE 4-4 Model 648 keypad and LED layout

Magnet water	Selects the magnet water setup menu.	4.13
Internal water	Selects the internal water setup menu.	4.14
Display setup	Sets the display brightness.	4.6
Escape	Exits from parameter setting sequence without changing the parameter value. Press and hold to reset parameters to default values.	4.19
External program	Setup the external current programming mode	4.16
Computer interface	Setup RS-232C and IEEE-488 computer interfaces	4.18
Ramp segments	Setup ramp segment values	4.9
Max settings	Setup maximum setting limits for output current, and ramp rate	4.12
Status	Displays a summary of the instrument status	4.15
Enter	Accepts a new parameter value; press and hold to lock keypad	4.17
0 to 9 ±,.	Numeric data entry within a setting sequence	4.5.1
(Up)	Increments a parameter selection or value.	4.5.1
(Down)	Decrements a parameter selection or value.	4.5.1
Output setting	Sets the output current	4.7
Ramp rate	Sets the output current ramp rate	4.8
Pause ramp	Pauses the output ramp and holds the current where it was paused; press again to continue to ramp	4.10
Zero output	Ramps the current to 0 A at the programmed ramp rate	4.11
Remote	Places the instrument to Remote mode	5.2.2
Local	Returns the instrument to Local mode if in Remote	5.2.2

TABLE 4-3 Model 648 key descriptions

4.5.1 General Keypad Operation

The Model 648 uses three basic keypad operations, direct operation, setting selection, and data entry, for the majority of operator interface. A few specialized keypad operations, such as ramp segment entry, are described in the individual operation paragraphs.

- **Direct Operation:** key functions occur immediately when the key is pressed. **Pause Ramp** and **Zero Output** are examples of keys that operate this way.
- **Setting Selection:** allows the user to select from a finite list of parameter values. During setting selection use the ▲ and ▼ keys to select a parameter value. Press **Enter** to accept the change and advance to the next parameter. Press **Escape** to cancel the change to that parameter and return to the normal display. Setting selection screens always include the message: Select with ▲▼.
- **Data Entry:** allows you to enter numeric parameter values using the data entry keys that are printed on the key tops. Data entry keys include numbers from 0 to 9, ± sign, and decimal point. The labels printed above the keys describe the key function during normal operation. When you press one of these keys and a data entry sequence is started, the keys follow the data entry functions printed on the key tops. Once the correct parameter value is entered, press **Enter** to accept the change and advance to next parameter. Press **Escape** once to clear the new value and restart the setting sequence. Press **Escape** again to return to the normal display. Data entry screens always include the message: Enter a value for.

Related setting selection and data entry sequences are often chained together under a single key. To skip over a parameter without changing its value, press **Enter** before pressing an arrow or number key. To return to the normal display in the middle of a setting sequence, press **Escape** before pressing an arrow or number key. Changes entered before you press **Escape** are kept.

4.6 Display Setup

The Display Setup allows you to set the display brightness. The vacuum fluorescent (VF) display on the Model 648 has four brightness settings between 25% and 100% that can be changed from the front panel. The brightness setting changes the entire VF display, but it does not affect the LED annunciators to the right of the display. Continuous use of the instrument at 100% brightness will reduce the operating life of the display; therefore, brightness of 25%, the default setting, is recommended for most applications. To change the display brightness, press **Display Setup** and the brightness setup will appear.

Menu Navigation:
Display Setup → (25%, 50%, 75%, 100%)
 Default: 25%
 Interface Command: **DISP**

4.7 Setting Output Current

The main purpose of the Model 648 electromagnet power supply is to supply a very precise and stable current to a magnet load. Before setting output current, make sure that the instrument is properly setup for the magnet system that is being used. This includes setting up the maximum output current (section 4.12.1) and maximum ramp rate (section 4.12.2). When a new output current setting is entered, the supply will ramp to the new setting at the current ramp rate, unless limited by the fixed compliance voltage. The ramping LED will be lit while the output current is ramping. When the output current setting is entered, it will be limited in magnitude by the maximum current setting. Refer to section 4.12.2 to setup the maximum settings.



The output current setting value can be set as high as ± 135.1000 A. This can be used to compensate for variances in calibration. The output current is guaranteed to reach a minimum of 135 A into a 0.5 Ω load but may not be able to reach 135.1 A in all circumstances.

The output current setting is not allowed to change if the instrument is set up so that the output current is programmed solely by an external voltage. The screen will read “change not allowed while in external current program mode.” Refer to section 4.16 to setup the external current program mode.

Menu Navigation:
Output Setting → (-135.000 to +135.000)
 Default: 0.0000 A
 Interface Command: **SETI**

4.8 Output Current Ramp Rate

The output current of the Model 648 will always ramp from one current setting to another. There is no way to turn off the current ramping function, but if a very fast ramp rate is desired, a ramp rate as high as 50.000 A/s can be entered.

Menu Navigation:
Ramp Rate → (0.0001 to 50.000)
 Default: 50.0000 A/s
 Interface Command: **RATE**

4.9 Ramp Segments

The magnetic field produced by electromagnets is not linear with the current setting. The best way to compensate for this is to use closed loop field control, but if absolute accuracy is not necessary, then some of this nonlinearity can be corrected by the use of the ramp segments feature.

The ramp segments feature can be used to increase the current ramp rate as the magnet saturates in an attempt to maintain the same field ramp rate. This feature can change the output current ramp rate based on the output current setting. As the output setting ramps through the segment boundary, the new ramp rate will be used, although it will still be limited by the maximum ramp rate setting. Refer to section 4.12.2 to set the maximum ramp rate. To enable ramp segments, press **Ramp Segments**. The first ramp segments setup screen appears as a prompt for the ramp segments mode.

Menu Navigation:
Ramp Segments → *(Enable, Disable)*
 Default: Enabled
 Interface Command: **RSEG**

4.9.1 Setting Up the Ramp Segments Table

To use the ramp segment feature, Ramp Segment mode must be enabled (section 4.9) and the ramp segment table must be set up to specify which ramp rate to use for each current setting. The table should be set up in order of increasing current. A current entry of 0 A indicates the end of the table, and the instrument will not search any higher in the table.

If the Ramp Segments mode is enabled, the next ramp segments screen that appears is for entering or editing the ramp segments table. All five of the ramp segments are shown on the display at the same time. The segments should be entered in order of increasing current. An entry of 0 A will indicate the end of the table and the instrument will not search beyond that segment. For example:

Ramp Segment	Current	Ramp Rate
1:	10.000 A	0.5000 A/s
2:	15.000 A	0.6000 A/s
3:	20.000 A	0.7000 A/s
4:	30.000 A	0.8000 A/s
5:	40.000 A	1.0000 A/s

1. When you enter the ramp segments table, the “1” is highlighted. Press **Enter** to move the cursor to the current column.
2. Using number entry, enter the upper current setting for that ramp segment in amperes.
3. When you have finished entering the desired current, press **Enter** to accept the new selection and advance to the ramp rate column.
4. Use number entry to enter the applicable ramp rate in A/s.
5. Press **Enter** to advance to the next segment.

Similarly enter or edit all ramp segments. When complete, press **Escape** while the segment number field is highlighted to exit the ramp segment edit screen and return to the normal display. When output current is called for using the **Output Setting** key, the output will ramp to the desired current using the ramp segment set points.

4.10 Pause Output

The **Pause Output** key will pause the output current ramp within 2 s after the key is pressed. While the output current ramp is paused, the ramping LED will blink. Press **Pause Output** again to continue ramping. Press **Enter** while the ramp is paused to set the current at the paused setting and exit the Pause Ramp mode.

4.11 Zero Output

The Zero Output key on the front panel can be used to set the output current to 0 A. When you press Zero Output, the current output will begin to ramp down using the current ramp rate that you set in section 4.8. This key is equivalent to using Output Setting and entering 0 A, except that it works even when the Model 648 is being programmed externally. Refer to section 4.7 to set the output current.



The current ramp rate applies only to the internal current output setting. When the Model 648 is programmed externally, the drop to zero output (when the Zero Output key is pressed) will be quite rapid (~1 second) and limited primarily by the magnet reactance and the Model 648 voltage compliance limit. The voltage compliance LED may light during the change.

4.12 Maximum Setting Limits

The Model 648 offers a maximum setting limit for output current and ramp rate. Typical properties of the magnet will dictate these parameters. These maximum parameters should be entered before the magnet system is used to prevent damage.

4.12.1 Maximum Output Current

Maximum Output Current limits the output current that can be entered when using the Output Setting key. This setting will only limit the internal output current setting. If the output current is being programmed by an external voltage, then some external provision must be made to insure that the programming voltage will never exceed the desired output current. Refer to section 4.16 to setup the External Current Programming mode.

To set the maximum output current limit press **Max Settings**. The first maximum setting screen appears as a prompt for the maximum output current limit.



The maximum output current limit value can be set as high as 135.1000 A. This can be used to compensate for variances in calibration. The output current is guaranteed to reach a minimum of 135 A into a 0.5 Ω load, but it may not be able to reach 135.1 A in all circumstances.

Menu Navigation:

Max Settings → (0.0000 A to 135.0000 A)

Default: 0.0000

Interface Command: **SETI**

4.12.2 Maximum Current Ramp Rate

Maximum Current Ramp Rate limits the maximum current ramp rate that can be entered using the Ramp Rate key. This setting will only limit the internal output current ramp setting. If ramp segments are being used, this setting will also limit the ramp rate that can be set by a ramp segment. Refer to section 4.9 to setup Ramp Segments.

Menu Navigation:

Max Settings → **ENTER** Maximum current ramp rate (0.0001 A/s to 50.000 A/s)

Default: Enabled

Interface Command: **RS**

4.13 Magnet Water

The Model 648 provides power to control an external magnet water solenoid control valve. The setup of the valve control is available in the magnet water menu. The four menu selections are Auto, On, Off, and Disabled, with Auto being the default setting.

- *Auto mode*: the water valve will be energized when the power in the magnet exceeds 200 W. When the power drops below 200 W, the valve will remain energized for an additional minute to remove any residual heat build-up.
- *On mode*: the valve will be energized whenever the power supply is on. This feature can be used when the system is first installed to purge air from the water lines and magnet. It can also be used to turn on the water in advance of a test to

bring the magnet temperature to equilibrium. The Off menu selection can be used to turn it off.

- *Disabled mode*: the Model 648 assumes that no valve is installed and the line for magnet water status will not be displayed.



The magnet water flow switch is monitored whenever the water valve is energized. It is also monitored continuously when in Disabled mode to allow the use of a flow switch even when no water valve is used. If no flow switch or water valve is present, then a jumper must be installed across the flow switch contacts for proper operation.

Menu Navigation:

Magnet Water → (*Auto, On, Off, Disabled*)

Default: Disabled

Interface Command: **MAGWTR**

4.14 Internal Water

The Model 648 provides power to control an external water solenoid control valve to control the cooling water for the power supply. The setup of the valve control is available in the internal water menu. The four menu selections are Auto, On, Off, and Disabled. Disabled is the default setting.

- *Auto mode*: the water valve will be energized when the power in the internal power devices exceeds 200 W. When the power drops below 200 W, the valve will remain energized for an additional minute to remove any residual heat build-up.
- *On mode*: the valve will be energized whenever the power supply is on. This feature can also be used when the Model 648 is first installed to purge air from the lines. The Off menu selection can be used to turn it off.
- *Disabled mode*: the Model 648 assumes that no valve is installed and the line for internal water status will not be displayed.



The internal water flow switch is monitored whenever the water valve is energized. It is also monitored continuously when in Disabled mode to allow the use of a flow switch even when no water valve is used. If no flow switch or water valve is present, then a jumper must be installed across the flow switch contacts for proper operation.

Menu Navigation:

Magnet Water → (*Auto, On, Off, Disabled*)

Default: Disabled

Interface Command: **INTWTR**

4.15 Error Status Display

Error messages appear in the center of the instrument display when a problem is identified during operation. The fault LED will also light to indicate error conditions, blinking for operational errors, and on continuously for instrument hardware errors. Refer to section 6.9 for a listing of all the error conditions. When an error condition occurs, the name of the error is shown in the display alternately with the message, “Press Status Key for More Info”. Press **Status** to bring up a screen that will show an extended description of the error.

To enter the error status display press **Status** while in the main display. A new screen appears. The screen will differ depending on the error that is being displayed. If there are no errors to report, the display message will read “No errors reported.”

Menu Navigation:

Status → Screen differs

Interface Command: **ERSTE**

4.16 External Current Programming

The output current of the Model 648 can be set internally, externally, or by the sum of the external and internal settings.

- *Internal:* (default) the current is controlled internally by entering a setting from the front panel using **Output Setting**. Refer to section 4.7 to set the output current.
- *External:* when the external program mode is set to external, the front panel setting is fixed at 0 A and the output current is set using an external voltage where $10\text{ V} = 135\text{ A}$.
- *Sum:* when the external program mode is set Sum, the internal and external settings are summed together to set the output current.

CAUTION

When using the **External** or **Sum** modes, care must be taken to insure that the output current does not exceed the maximum current for the magnet. The software maximum setting limits cannot limit the output current or ramp rate that is set when using the **External** or **Sum** modes. Failure to comply may result in damage to the magnet.

NOTE

A -3 dB, 40 Hz, two-pole, low-pass filter limits the bandwidth of the external current programming input. The bandwidth of the output is also limited by the compliance voltage and the inductance of the magnet.

Menu Navigation:

External Program → (*Internal, External, Sum*)

Interface Command: **ER**

To avoid discontinuities in the output current, the external current programming mode cannot be changed if the programming voltage or the front panel current setting is not zero. If the external current program mode is going to be kept from changing, an error box will pop up explaining why the new setting is being ignored.

4.17 Locking the Keypad

The keypad lock feature prevents accidental changes to parameter values. When the keypad is locked, parameter values may be viewed but not changed from the front panel. The Model 648 has two keypad lock modes.

- *Lock All mode:* locks out changes to all parameters.
- *Lock Limits mode:* locks out changes to all of the parameters except **Output Setting**, **Ramp Rate**, **Zero Output** and **Pause Ramp**. This allows the power supply to be operated without allowing any changes to the power supply setup.

A 3-digit code must be used to lock and unlock the keypad. The factory default code is 123, and it can only be changed using a computer interface. If the instrument parameters are reset to default values (section 4.19), the code is reset to the factory default. The instrument parameters cannot be reset to default values from the front panel when the keypad is locked. If you attempt to change a parameter while the keypad is locked you will receive this message: Change not allowed while keypad is locked.

NOTE

The computer interface has a remote operation mode that could be mistaken for a locked keypad. If the front panel remote LED is lit, press **Local** to change to local control of the instrument.

Once the keypad lock mode has been selected, the keypad lock code must be entered to accept the change. Use the data entry keys to enter the 3-digit lock code (default 123). An asterisk will appear on the display for each number entered. If the code entered matches the lock code, the display will show “Change Accepted” and the keypad lock mode will be updated. If the code entered does not match the lock code, the display will show “Invalid Lock Code” and the keypad lock mode will not change.

Menu Navigation:

ENTER (Press and hold for 3 s) → (*Unlock, Lock All, Lock Limits*) → Keypad lock code

Default: **Unlock**

Interface Command: **LOCK**

4.18 Computer Interface

There are two computer interfaces on the Model 648, a USB interface and an IEEE-488 interface. These interfaces are used to connect the instrument to a computer for automated control or data taking. Refer to Chapter 5. Section 4.18.1 explains how to change the interface parameters on the IEEE-488 interface.

4.18.1 Changing IEEE-488 Interface Parameters

Two interface parameters, address and terminators, must be set from the front panel before IEEE-488 communication with the instrument can be established. Other interface parameters can be set via the interface using the device specific commands provided in section 5.4.

Menu Navigation:

Computer Interface → IEEE Address (1 to 30) **ENTER** → IEEE Term (Cr Lf, EOI, LF, LFCR)

Interface Command: **IEEE**

4.19 Default Parameter Values

It is sometimes desirable to reset instrument parameters to their default values. This data is stored in nonvolatile memory called EEPROM. Instrument calibration is not affected by this operation. Firmware version information for the main firmware and the DAC firmware is also displayed during this sequence.

To clear EEPROM memory or view the firmware versions, press and hold **Escape** for 5 s. A screen appears to show the main firmware version, the DAC processor firmware version, and is a prompt for returning the instrument parameters to default values. Default parameter values are listed in TABLE 4-4.

Output settings	Output current*	0 A
	Current ramp rate	50.000 A/s
Maximum settings	Max output current	135.1 A
	Max ramp rate	50.000 A/s
External program mode	External program mode	Internal
Ramp segments	Ramp segments	Disabled
	Ramp segments current	0 A
	Ramp segments rate	1.0000 A/s
Display	Brightness	25%
Keypad locking	State	Unlocked
	Lock code	123
Computer interface	Baud	57,600
	IEEE-488 address	12
	IEEE-488 terminators	CR/LF
	Mode*	Local
Water settings	Magnet water	Disabled
	Internal water	Disabled

* Indicates value is also initialized on power up

TABLE 4-4 Default parameter values

Menu Navigation:

Escape (Press and hold for 5 s) → (Yes, No)

Interface Command: **DFLT**

Chapter 5: Computer Interface Operation

5.1 General

This chapter provides operational instructions for the computer interface for the Lake Shore Model 648 electromagnet power supply. Either of the two computer interfaces provided with the Model 648 permit remote operation. The first is the IEEE-488 Interface described in section 5.2. The second is the serial Interface described in section 5.3. The two interfaces share a common set of commands detailed in section 5.4. Only one interface can be used at a time.

5.2 IEEE-488 Interface

The IEEE-488 interface is an instrumentation bus with hardware and programming standards that simplify instrument interfacing. The Model 648 IEEE-488 interface complies with the IEEE-488.2 standard and incorporates its functional, electrical, and mechanical specifications unless otherwise specified in this manual.

All instruments on the interface bus perform one or more of the interface functions of Talker, Listener, or Bus Controller. A Talker transmits data onto the bus to other devices. A Listener receives data from other devices through the bus. The Bus Controller designates to the devices on the bus which function to perform. The Model 648 performs the functions of Talker and Listener, but it cannot be a Bus Controller. The Bus Controller is the digital computer that tells the Model 648 which functions to perform.

TABLE 5-1 defines the IEEE-488 capabilities and subsets for the Model 648:

Subset	Capabilities
SH1:	Source handshake capability
RL1:	Complete remote/local capability
DC1:	Full device clear capability
DT0:	No device trigger capability
CO:	No system controller capability
T5:	Basic Talker, serial poll capability, talk only, unaddressed to talk if addressed to listen
L4:	Basic Listener, unaddressed to listen if addressed to talk
SR1:	Service request capability
AH1:	Acceptor handshake capability
PP0:	No parallel poll capability
E1:	Open collector electronics

TABLE 5-1 Model 648 IEEE-488 interface capabilities and their subsets

Instruments are connected to the IEEE-488 bus by a 24-conductor connector cable as specified by the standard. Cables can be ordered from Lake Shore as IEEE-488 Cable Kit 4005, or they can be purchased from other electronic suppliers.

Cable lengths are limited to 2 m (6.6 ft) for each device and 20 m (65.6 ft) for the entire bus. The Model 648 can drive a bus with up to ten loads. If more instruments or cable length is required, a bus expander must be used.

5.2.1 Changing IEEE-488 Interface Parameters

The IEEE-488 address must be set from the front panel before communication with the instrument can be established.

Menu Navigation:

Interface→Enabled→IEEE-488

Interface→IEEE-488 Address→(1 to 31)

Default: IEEE-488.

5.2.2 Remote/Local Operation

Normal operations from the keypad are referred to as local operations. The Model 648 can also be configured for remote operations via the IEEE-488 interface or the **Remote/Local** key. The **Remote/Local** key will toggle between remote and local operation. During remote operations, the remote annunciator LED will be illuminated, and operations from the keypad will be disabled.

5.2.3 IEEE-488 Command Structure

The Model 648 supports several command types. These commands are divided into four groups.

1. Bus control (section 5.2.3.1)
 - a. Universal
 - Uniline
 - Multiline
 - b. Addressed Bus Control
2. Common (section 5.2.3.2)
3. Device specific (section 5.2.3.3)
4. Message strings (section 5.2.3.4)

5.2.3.1 Bus Control Commands

A bus control command can either be a universal or an addressed bus control. A universal command addresses all devices on the bus. Universal commands include uniline and multiline commands. A uniline command (message) asserts only a single signal line. The Model 648 recognizes two of these messages from the Bus Controller: Remote (REN) and Interface Clear (IFC). The Model 648 sends one uniline command: Service Request (SRQ).

- REN (Remote): puts the Model 648 into remote mode
- IFC (Interface Clear): stops current operation on the bus
- SRQ (Service Request): tells the bus controller that the Model 648 needs interface service

A multiline command asserts a group of signal lines. All devices equipped to implement such commands do so simultaneously upon command transmission. These commands transmit with the Attention (ATN) line asserted low. The Model 648 recognizes two multiline commands:

- LLO (Local Lockout): prevents the use of instrument front panel controls
- DCL (Device Clear): clears Model 648 interface activity and puts it into a bus idle state

Finally, addressed bus control commands are multiline commands that must include the Model 648 listen address before the instrument responds. Only the addressed device responds to these commands. The Model 648 recognizes three of the addressed bus control commands:

- SDC (Selective Device Clear): the SDC command performs essentially the same function as the DCL command, except that only the addressed device responds
- GTL (Go To Local): the GTL command is used to remove instruments from the remote mode. With some instruments, GTL also unlocks front panel controls if they were previously locked out with the LLO command.

- SPE (Serial Poll Enable) and SPD (Serial Poll Disable): serial polling accesses the Service Request Status Byte Register. This status register contains important operational information from the unit requesting service. The SPD command ends the polling sequence.

5.2.3.2 Common Commands

Common commands are addressed commands which create commonality between instruments on the bus. All instruments that comply with the IEEE-488 1987 standard share these commands and their format. Common commands all begin with an asterisk. They generally relate to “bus” and “instrument” status and identification. Common query commands end with a question mark (?). Model 648 common commands are detailed in section 5.4 and summarized in TABLE 5-7.

5.2.3.3 Device Specific Commands

Device specific commands are addressed commands. The Model 648 supports a variety of device specific commands to program instruments remotely from a digital computer and to transfer measurements to the computer. Most device specific commands perform functions also performed from the front panel. Model 648 device specific commands are detailed in section 5.4 and summarized in TABLE 5-7.

5.2.3.4 Message Strings

A message string is a group of characters assembled to perform an interface function. There are three types of message strings: commands, queries and responses. The computer issues command and query strings through user programs, and the instrument issues responses. Two or more command strings or queries can be chained together in one communication, but they must be separated by a semi-colon (;). The total communication string must not exceed 255 characters in length.

A command string is issued by the computer and instructs the instrument to perform a function or change a parameter setting. When a command is issued, the computer is acting as talker and the instrument as listener. The format is:

<command mnemonic><space><parameter data><terminator>.

Command mnemonics and parameter data necessary for each one is described in section 5.4. A terminator must be sent with every message string.

A query string is issued by the computer and instructs the instrument which response to send. Queries are issued similar to commands with the computer acting as talker and the instrument as listener. The query format is:

<query mnemonic><?><space><parameter data><terminator>.

Query mnemonics are often the same as commands with the addition of a question mark. Parameter data is often unnecessary when sending queries. Query mnemonics and parameter data if necessary is described in section 5.4. A terminator must be sent with every message string. Issuing a query does not initiate a response from the instrument.

A response string is sent by the instrument only when it is addressed as a talker and the computer becomes the listener. The instrument will respond only to the last query it receives. The response can be a reading value, status report or the present value of a parameter. Response data formats are listed along with the associated queries in section 5.4.

5.2.4 Status System Overview

The Model 648 implements a status system compliant with the IEEE-488.2 standard. The status system provides a method of recording and reporting instrument information and is typically used to control the Service Request (SRQ) interrupt line. A diagram of the status system is shown in FIGURE 5-1. The status system is made up of status register sets, the Status Byte register, and the Service Request Enable register. Each register set consists of three types of registers: condition, event, and enable.

5.2.4.1 Condition Registers

Each register set (except the Standard Event Register set) includes a condition register as shown in FIGURE 5-1. The condition register constantly monitors the instrument status. The data bits are real-time and are not latched or buffered. The register is read-only.

5.2.4.2 Event Registers

Each register set includes an event register as shown in FIGURE 5-1. Bits in the event register correspond to various system events and latch when the event occurs. When an event bit is set, subsequent events corresponding to that bit are ignored. Set bits remain latched until the register is cleared by a query command (such as *ESR?) or a *CLS command. The register is read-only.

5.2.4.3 Enable Registers

Each register set includes an enable register as shown in FIGURE 5-1. An enable register determines which bits in the corresponding event register will set the summary bit for the register set in the Status Byte. You may write to or read from an enable register. Each event register bit is logically ANDed to the corresponding enable bit of the enable register. When you set an enable register bit, and the corresponding bit is set in the event register, the output (summary) of the register will be set, which in turn sets the summary bit of the Status Byte register.

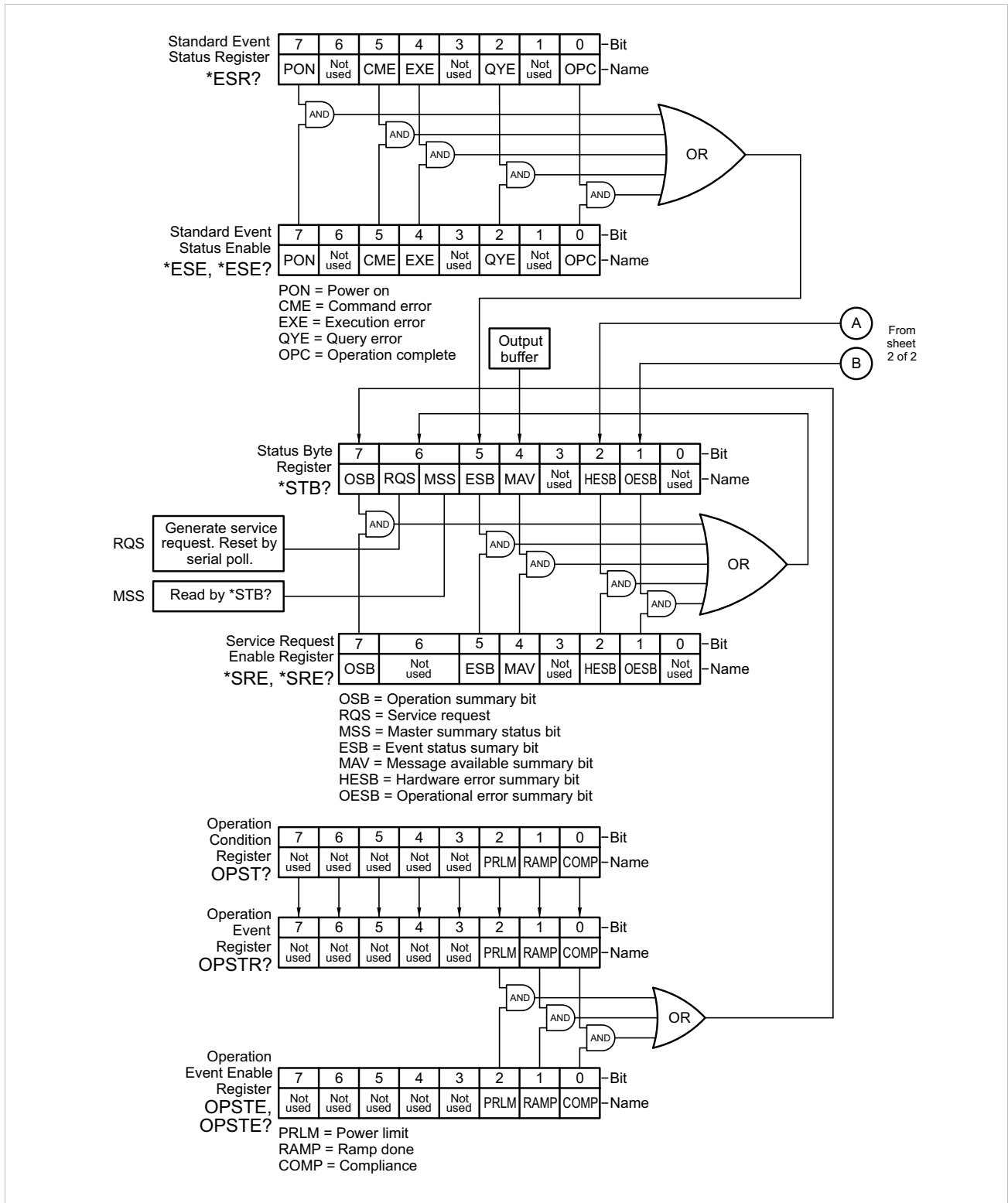
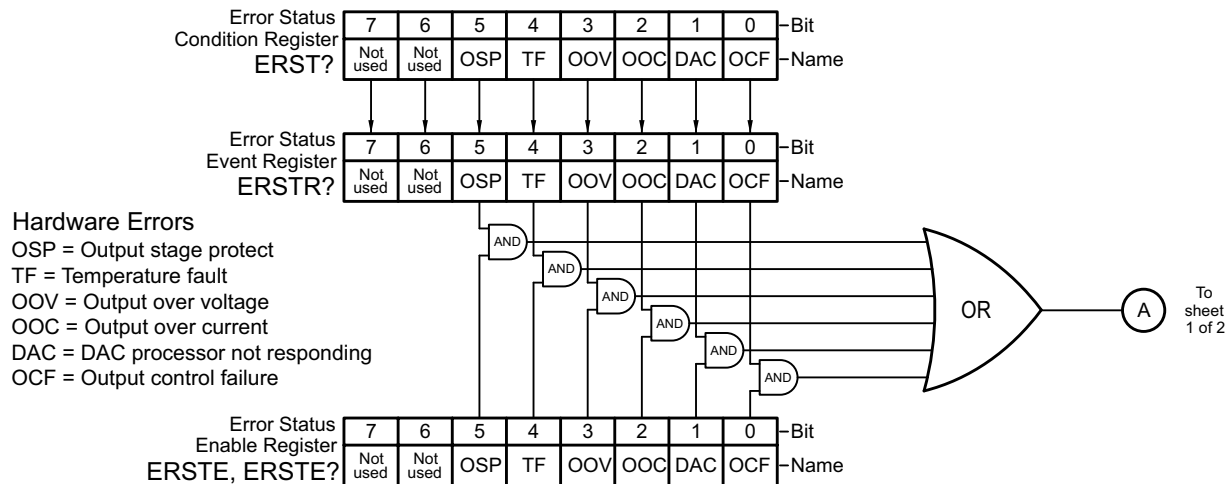

FIGURE 5-1 Model 648 status system (image 1 of 2)



NOTE: ERST, ERSTR, and ERSTE set and return two bytes:
 <hardware errors>, <operational errors>

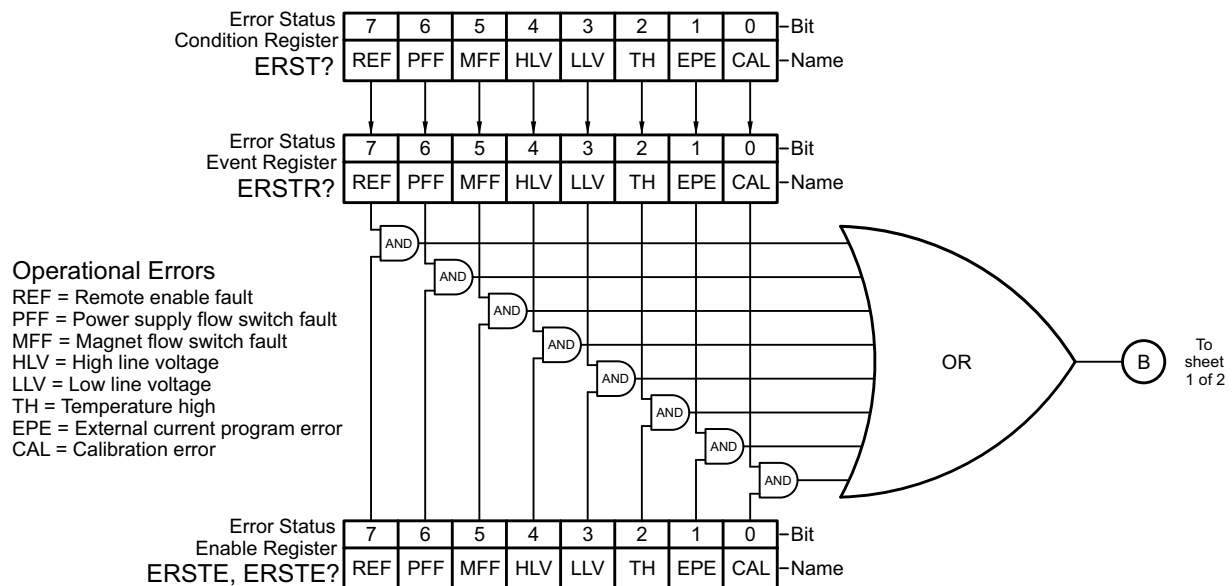

FIGURE 5-2 Model 648 status system (image 2 of 2)

5.2.4.4 Status Byte Register

The Status Byte register, typically referred to as the Status Byte, is a non-latching, read-only register that contains all of the summary bits from the register sets. The status of the summary bits are controlled from the register sets as explained in section 5.2.4.1 to section 5.2.4.3. The Status Byte also contains the Request for Service (RQS)/Master Summary Status (MSS) bit. This bit is used to control the Service Request hardware line on the bus and to report if any of the summary bits are set via the *STB? command. The status of the RQS/MSS bit is controlled by the summary bits and the Service Request Enable Register

5.2.4.5 Service Request Enable Register

The Service Request Enable Register determines which summary bits in the Status Byte will set the RQS/MSS bit of the Status Byte. You may write to or read from the Service Request Enable Register. Each Status Byte summary bit is logically ANDed to the corresponding enable bit of the Service Request Enable Register. When you set a Service Request Enable Register bit, and the corresponding summary bit is set in the Status Byte, the RQS/MSS bit of the Status Byte will be set, which in turn sets the Service Request hardware line on the bus.

5.2.4.6 Reading Registers

You can read any register in the status system using the appropriate query command. Some registers clear when read, others do not (section 5.2.4.8). The response to a query will be a decimal value that corresponds to the binary-weighted sum of all bits in the register (TABLE 5-2). The actual query commands are described later throughout section 5.2.4.

Position	B7	B6	B5	B4	B3	B2	B1	B0
Decimal	128	64	32	16	8	4	2	1
Weighting	2 ⁷	2 ⁶	2 ⁵	2 ⁴	2 ³	2 ²	2 ¹	2 ⁰

Example: If bits 0, 2, and 4 are set, a query of the register will return a decimal value of 21 (1+4+16).

TABLE 5-2 Binary weighting of an 8-bit register

5.2.4.7 Programming Registers

The only registers that may be programmed by the user are the enable registers. All other registers in the status system are read-only registers. To program an enable register, send a decimal value that corresponds to the desired binary-weighted sum of all bits in the register (TABLE 5-2). The actual commands are described throughout (section 5.2.4).

5.2.4.8 Clearing Registers

The methods to clear each register are detailed in TABLE 5-3.

Register	Method	Example
Condition registers	None. Registers are not latched	—
Event registers: Standard event status register Operation event register	Query the event register	*ESR? (clears Standard Event Status Register)
	Send *CLS	*CLS (clears both registers)
	Power on instrument	—
Enable registers Standard Event Status Enable Register Operation Event Enable Register Service Request Enable Register	Write 0 to the enable register	*ESE 0 (clears Standard Event Status Enable register)
	Power on instrument	—
Status byte	There are no commands that directly clear the status byte as the bits are non-latching; to clear individual summary bits clear the event register that corresponds to the summary bit—sending *CLS will clear all event registers which in turn clears the status byte	If bit 5 (ESB) of the status byte is set, send *ESR? to read the standard event status register and bit 5 will clear
	Power on instrument	—

TABLE 5-3 Register clear methods

5.2.5 Status System Detail: Status Register Sets

As shown in FIGURE 5-1, there are two register sets in the status system of the Model 648: Standard Event Status Register and Operation Event Register.

5.2.5.1 Standard Event Status Register Set

The Standard Event Status Register reports the following interface related instrument events: power on detected, command syntax errors, command execution errors, query errors, operation complete. Any or all of these events may be reported in the standard event summary bit through the enable register (FIGURE 5-2). The Standard Event Status Enable command (*ESE) programs the enable register and the query command (*ESE?) reads it. *ESR? reads and clears the Standard Event Status Register. The used bits of the Standard Event Register are described as follows:

- Power On (PON), Bit (7): this bit is set to indicate an instrument off-on transition.
- Command Error (CME), Bit (5): this bit is set if a command error has been detected since the last reading. This means that the instrument could not interpret the command due to a syntax error, an unrecognized header, unrecognized terminators, or an unsupported command.
- Execution Error (EXE), Bit (4): this bit is set if an execution error has been detected. This occurs when the instrument is instructed to do something not within its capabilities.
- Query Error (QYE), Bit (2): this bit indicates a query error. It occurs rarely and involves loss of data because the output queue is full.
- Operation Complete (OPC), Bit (0): when *OPC is sent, this bit will be set when the instrument has completed all pending operations. The operation of this bit is not related to the *OPC? command, which is a separate interface feature (section 5.2.7.6).

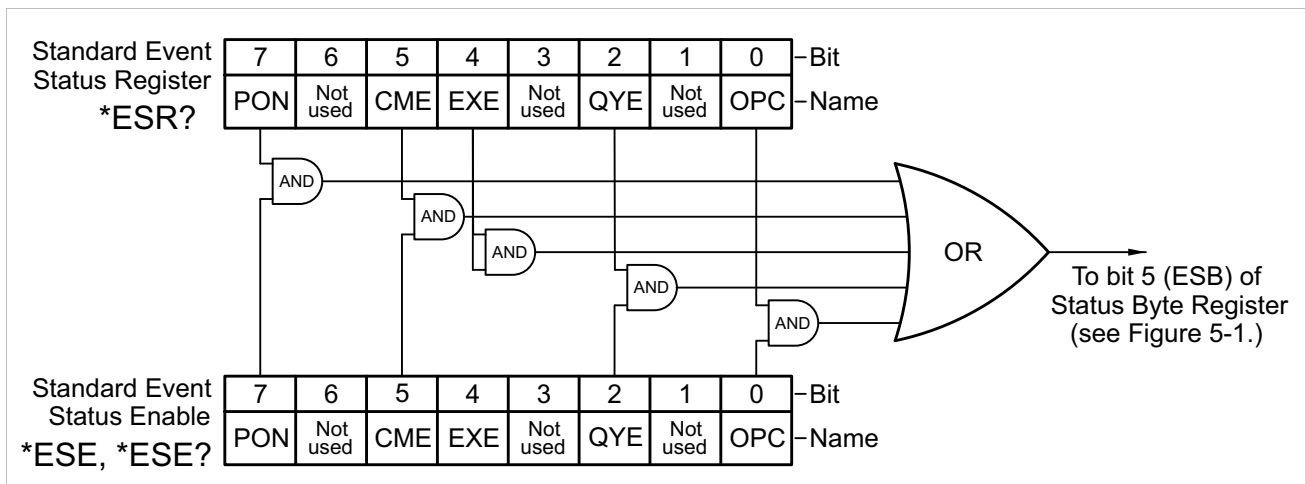

FIGURE 5-3 Standard event status register

5.2.5.2 Operation Event Register Set

The Operation Event Register reports the following instrument events: ramp done, compliance. Any or all of these events may be reported in the operation event summary bit through the enable register, see Figure 5-3. The Operation Event Enable command (OPSTE) programs the enable register and the query command (OPSTE?) reads it. OPSTR? reads the Operation Event Register. OPST? reads and clears the Operation Condition register. The used bits of the Operation Event Register are described as follows:

- Power Limit, Bit (2): this bit is set if the output is in power limit.
- Ramp Done, Bit (1): this bit is set when the output current ramp is completed.
- Compliance, Bit (0): this bit is set if the output is in compliance limit.

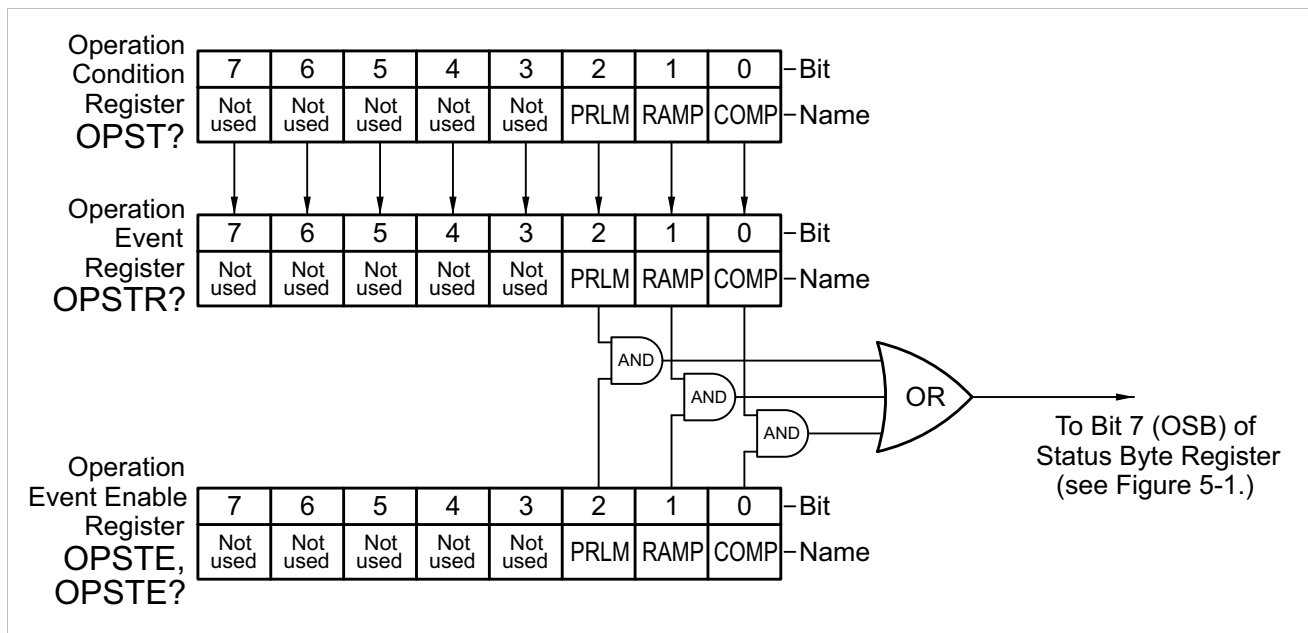

FIGURE 5-4 Operation event register

5.2.6 Status System Detail: Error Status Register Sets

As shown in Figure 5-1, there are two register sets in the error status system of the Model 642; Hardware Error Status Register, and Operational Error Status Register.

5.2.6.1 Hardware Error Status Register Set

The Hardware Error Status Register reports the following instrument hardware error events: temperature fault, output over voltage, output over current, DAC processor not responding, output control failure, and output stage protect. Any or all of these events may be reported in the standard event summary bit through the enable register, see Figure 5-4. The Hardware Error Status Register is the first value of the two values associated with the Error Status Registers. The Error Status Enable command (ERSTE) programs the enable register and the query command (ERSTE?) reads it. ERSTR? reads and clears the Error Status Register. The used bits of the Error Status Event Register are described as follows:

- Output Stage Protect (OSP), Bit (5): this bit is set if the output stage protection is enabled. This may be a recoverable error, or it may indicate a hardware failure.
- Temperature Fault (TF), Bit (4): this bit is set if the internal temperature of the instrument exceeded the maximum safe value. The instrument will shut down within 10 seconds of detecting this fault.
- Output Over Voltage (OOV), Bit (3): this bit is set if the output voltage exceeded the compliance voltage limit setting.
- Output Over Current (OOC), Bit (2): this bit is set if the output current exceeds the maximum output current of the instrument. The instrument will shut down within 10 seconds of detecting this fault.
- DAC Processor Not Responding (DAC), Bit (1): this bit is set to indicate that communication to the DAC processor has failed.
- Output Control Failure (OCF), Bit (0): this bit is set if there is a failure on the output control board.

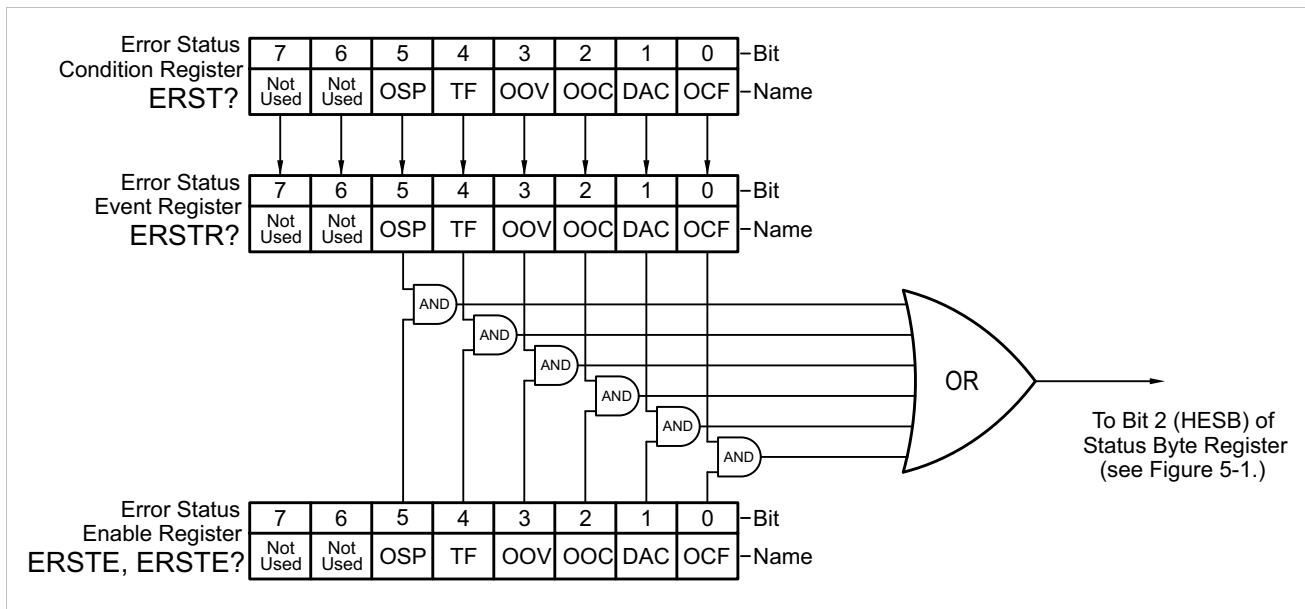

FIGURE 5-5 Hardware error status register

5.2.6.2 Operational Error Status Register Set

The Operational Error Status Register reports the following instrument operational error events: remote enable fault detected, power supply flow switch fault detected, magnet flow switch fault detected, high line voltage, low line voltage, temperature high, external current program error, calibration error. Any or all of these events may be reported in the standard event summary bit through the enable register, see Figure 5-5. The Operational Error Status Register is the second value of the two values associated with the Error Status Registers. The Error Status Enable command (ERSTE) programs the enable register and the query command (ERSTE?) reads it. ERSTR? reads and clears the Error Status Register. The used bits of the Error Status Event Register are described as follows:

- Remote Enable Fault Detected (REF), Bit (7): this bit is set if a fault condition is detected on the remote enable interlock.
- Power Supply Flow Switch Fault Detected (PFF), Bit (6): this bit is set if a fault condition is detected on the power supply flow switch interlock.
- Magnet Flow Switch Fault Detected (MFF), Bit (5): this bit is set if a fault condition is detected on the magnet flow switch interlock.
- High Line Voltage (HLV), Bit (4): this bit is set if the power line voltage exceeds an acceptable amplitude. Operation can continue but additional heat may be dissipated by the instrument.
- Low Line Voltage (LLV), Bit (3): this bit is set if the power line voltage drops below an acceptable amplitude. Operation can continue but output voltage may not reach maximum specification.
- Temperature High (TH), Bit (2): this bit is set if the internal temperature of the instrument exceeded 40 °C. The output current will be set to zero and will not be settable until the fault is cleared.
- External Current Program Error (EPE), Bit (1): this bit is set if the instrument cannot go into external or sum current programming modes because the programming voltage is too high. The output current will be set to zero and will not be settable until the fault is cleared.
- Calibration Error (CAL), Bit (0): this bit is set if the instrument is not calibrated or the calibration data has been corrupted

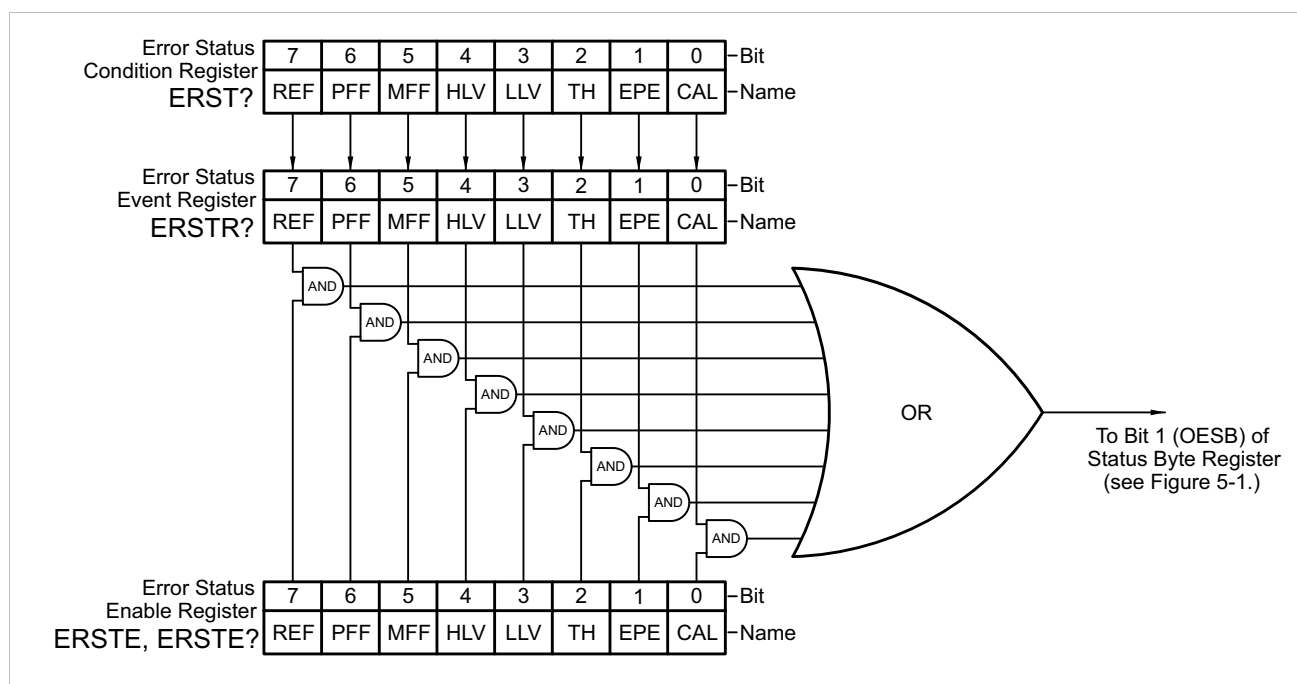

FIGURE 5-6 Operational error status register

5.2.7 Status System Detail: Status Byte Register and Service Request (SRQ)

As shown in Figure 5-1, the Status Byte Register receives the summary bits from the two status register sets and the message available summary bit from the output buffer. The status byte is used to generate a service request (SRQ). The selection of summary bits that will generate an SRQ is controlled by the Service Request Enable Register.

5.2.7.1 Status Byte Register

The summary messages from the event registers and output buffer set or clear the summary bits of the Status Byte Register (FIGURE 5-4). These summary bits are not latched. Clearing an event register will clear the corresponding summary bit in the Status Byte Register. Reading all messages in the output buffer, including any pending queries, will clear the message available bit. The bits of the Status Byte Register are described as follows:

- Operation Summary (OSB), Bit (7): set summary bit indicates that an enabled operation event has occurred.
- Request Service (RQS)/Master Summary Status (MSS), Bit (6): this bit is set when a summary bit and the summary bits corresponding enable bit in the Service Request Enable Register are set. Once set, the user may read and clear the bit in two different ways, which is why it is referred to as both the RQS and the MSS bit. When this bit goes from low to high, the Service Request hardware line on the bus is set, this is the RQS function of the bit. See section 5.2.4.5. In addition, the status of the bit may be read with the *STB? query which returns the binary weighted sum of all bits in the Status Byte, this is the MSS function of the bit.

Performing a serial poll will automatically clear the RQS function but not the MSS function. An *STB? will read the status of the MSS bit (along with all of the summary bits), but also will not clear it. To clear the MSS bit, either clear the event register that set the summary bit or disable the summary bit in the Service Request Enable Register.

- Event Summary (ESB), Bit (5): set summary bit indicates that an enabled standard event has occurred.

- Message Available (MAV), Bit (4): set summary bit indicates that a message is available in the output buffer.
- Bit (3): not used.
- Hardware Errors Summary (HESB), Bit (2): set summary bit indicates that an enabled hardware error event has occurred.
- Operational Errors Summary (OESB), Bit (1): set summary bit indicates that an enabled operational error event has occurred.

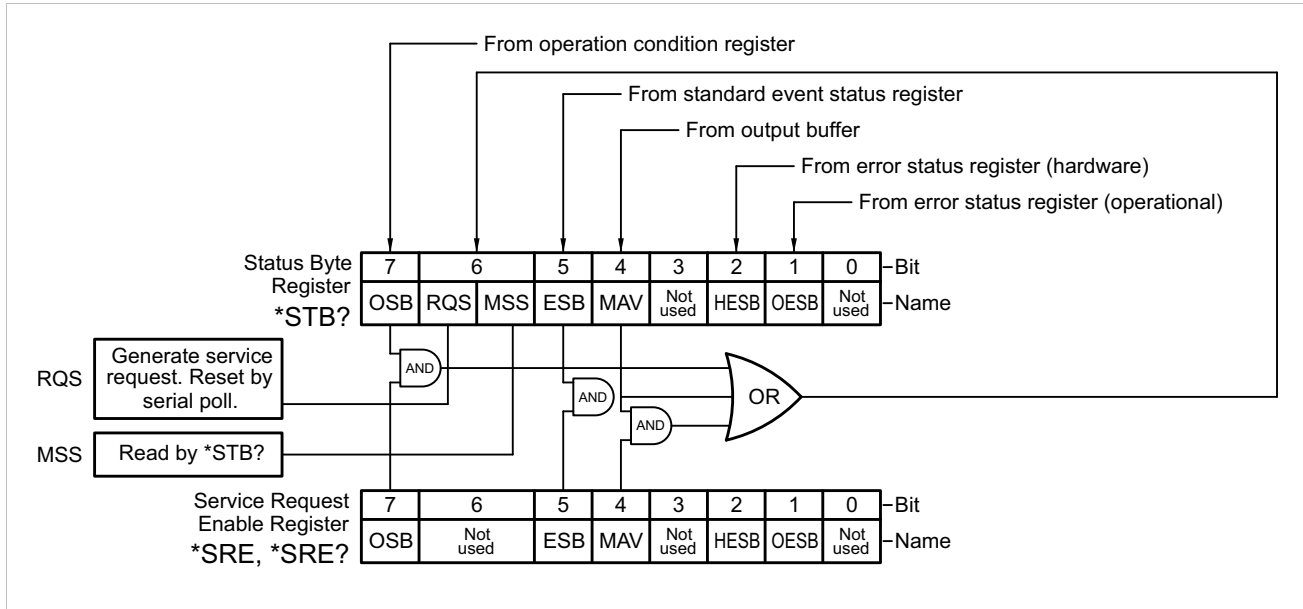

FIGURE 5-7 Status byte register and service request enable register

5.2.7.2 Service Request Enable Register

The Service Request Enable Register is programmed by the user and determines which summary bits of the Status Register may set bit 6 (RQS/MSS) to generate a Service Request. Enable bits are logically ANDed with the corresponding summary bits, see Figure 5-6. Whenever a summary bit is set by an event register and its corresponding enable bit is set by the user, bit 6 will set to generate a service request. The Service Request Enable command (*SRE) programs the Service Request Enable Register and the query command (*SRE?) reads it. Reading the Service Request Enable Register will not clear it. The register may be cleared by the user by sending *SRE 0.

5.2.7.3 Using Service Request (SRQ) and Serial Poll

When a Status Byte summary bit (or MAV bit) is enabled by the Service Request Enable Register and goes from 0 to 1, bit 6 (RQS/MSS) of the status byte will be set. This will send a service request (SRQ) interrupt message to the bus controller. The user program may then direct the bus controller to serial poll the instruments on the bus to identify which one requested service (the one with bit 6 set in its status byte).

Serial polling will automatically clear RQS of the Status Byte Register. This allows subsequent serial polls to monitor bit 6 for an SRQ occurrence generated by other event types. After a serial poll, the same event or any event that uses the same Status Byte summary bit, will not cause another SRQ unless the event register that caused the first SRQ has been cleared, typically by a query of the event register.

The serial poll does not clear MSS. The MSS bit stays set until all enabled Status Byte summary bits are cleared, typically by a query of the associated event register (section 5.2.7.4).

The programming example in TABLE 5-4 initiates an SRQ when a command error is detected by the instrument.

The programming example in Table 5-3 initiates an SRQ when a command error is detected by the instrument.

Command or operation	Description
*ESR?	Read and clear the Standard Event Status Register
*ESE 32	Enable the Command Error (CME) bit in the Standard Event Status Register
*SRE 32	Enable the Event Summary Bit (ESB) to set the RQS
*ABC	Send improper command to instrument to generate a command error
Monitor bus	Monitor the bus until the Service Request interrupt (SRQ) is sent
Initiate Serial Poll	Serial Poll the bus to determine which instrument sent the interrupt and clear the RQS bit in the Status Byte
*ESR?	Read and clear the Standard Event Status Register allowing an SRQ to be generated on another command error

TABLE 5-4 Programming example to generate an SRQ

5.2.7.4 Using Status Byte Query (*STB?)

The Status Byte Query (*STB?) command is similar to a Serial Poll except it is processed like any other instrument command. The *STB? command returns the same result as a Serial Poll except that the Status Byte bit 6 (RQS/MSS) is not cleared. In this case bit 6 is considered the MSS bit. Using the *STB? command does not clear any bits in the Status Byte Register.

5.2.7.5 Using Message Available (MAV) Bit

Status Byte summary bit 4 (MAV) indicates that data is available to read into your bus controller. This message may be used to synchronize information exchange with the bus controller. The bus controller can, for example, send a query command to the Model 642 and then wait for MAV to set. If the MAV bit has been enabled to initiate an SRQ, the user's program can direct the bus controller to look for the SRQ leaving the bus available for other use. The MAV bit will be clear whenever the output buffer is empty.

5.2.7.6 Using Operation Complete (*OPC) and Operation Complete Query (*OPC?)

The Operation Complete (*OPC) and Operation Complete Query (*OPC?) are both used to indicate when pending device operations complete. However, the commands operate with two distinct methods.

The *OPC command is used in conjunction with bit 0 (OPC) of the Standard Event Status Register. If *OPC is sent as the last command in a command sequence, bit 0 will be set when the instrument completes the operation that was initiated by the command sequence. Additional commands may be sent between the instrument and the bus controller while waiting for the initial pending operation to complete. A typical use of this function would be to enable the OPC bit to generate an SRQ and include the *OPC command when programming the instrument. The bus controller could then be instructed to look for an SRQ allowing additional communication with the instrument while the initial process executes.

The *OPC? query has no interaction with bit 0 (OPC) of the Standard Event Status Register. If the *OPC? query is sent at the end of a command sequence, the bus will be held until the instrument completes the operation that was initiated by the command sequence. Additional commands (except *RST) should not be sent until the operation is complete as erratic operation will occur. Once the sequence is complete a 1 will be placed in the output buffer. This function is typically used to signal a completed operation without monitoring the SRQ. It is also used when it is important to prevent any additional communication on the bus during a pending operation.

5.3 Serial Interface Overview

The Model 648 USB interface provides a convenient way to connect to most modern computers, as a USB interface is provided on nearly all new PCs as of the writing of this manual. The USB interface is implemented as a virtual serial com port connection. This implementation provides a simple migration path for modifying existing RS-232 based remote interface software. It also provides a simpler means of communicating than a standard USB implementation.

5.3.1 Physical Connection

The Model 648 has a B-type USB connector on the rear panel. This is the standard connector used on USB peripheral devices, and it allows the common USB A-type to B-type cable to be used to connect the Model 648 to a host PC. The pin assignments for A-type and B-type connectors are shown in section 6.11.5. The maximum length of a USB cable, as defined by the USB 2.0 standard, is 5 m (16.4 ft). This length can be extended using USB hubs every 5 m (16.4 ft) up to five times, for a maximum total length of 30 m (98.4 ft).

5.3.2 Hardware Support

The USB interface emulates an RS-232 serial port at a fixed 57,600 baud rate, but with the physical connections of a USB. This programming interface requires a certain configuration to communicate properly with the Model 648. The proper configuration parameters are listed in TABLE 5-5.

Baud rate	57,600
Data bits	7
Start bits	1
Stop bits	1
Parity	Odd
Flow control	None
Handshaking	None

TABLE 5-5 *Host com port configuration*

The USB hardware connection uses the full speed (12,000,000 bits/sec) profile of the USB 2.0 standard; however, since the interface uses a virtual serial com port at a fixed data rate, the data throughput is still limited to a baud rate of 57,600 bits/s.

5.3.3 Installing the USB Driver

The Model 648 USB driver has been made available through Windows® Update. This is the recommended method for installing the driver, as it will ensure that you always have the latest version of the driver installed. If you are unable to install the driver from Windows® Update, refer to section 5.3.3.3 to install the driver from the web or from the disc provided with the Model 648.

These procedures assume that you are logged into a user account that has administrator privileges.

5.3.3.1 Installing the Driver From Windows® Update in Windows Vista® and Windows 7®

1. Connect the USB cable from the Model 648 to the computer.
2. Turn on the Model 648.
3. When the Found New Hardware wizard appears, select **Locate and install driver software (recommended)**.
4. If User Account Control (UAC) is enabled, a UAC dialog box may appear asking if you want to continue. Click **Continue**.
5. The Found New Hardware wizard should automatically connect to Windows® Update and install the drivers.



If the Found New Hardware wizard is unable to connect to Windows® Update or find the drivers, a message to “Insert the disc that came with your Lake Shore Model 648” will be displayed. Click Cancel and refer to section 5.3.3.3 to install the driver from the web.

6. When the Found New Hardware wizard finishes installing the driver, a confirmation message stating “the software for this device has been successfully installed” will appear. Click **Close** to complete the installation.

5.3.3.2 Installing the Driver From Windows® Update in Windows® XP

1. Connect the USB cable from the Model 648 to the computer.
2. Turn on the Model 648.
3. When the Found New Hardware wizard appears, select **Yes, this time only** and click **Next**.
4. Select **Install the software automatically (Recommended)** and click **Next**.
5. The Found New Hardware wizard should automatically connect to Windows® Update and install the drivers.



If the Found New Hardware wizard is unable to connect to Windows® Update or find the drivers, a message saying Cannot Install this Hardware will be displayed. Click the Cancel button and refer to section 5.3.3.3 to install the driver from the web.

6. When the Found New Hardware wizard finishes installing the driver a confirmation message stating “the wizard has finished installing the software for Lake Shore Model 648 electromagnet power supply” will appear. Click **Finish** to complete the installation.

5.3.3.3 Installing the Driver From the Web

The Model 648 USB driver is available on the Lake Shore website. To install the driver it must be downloaded from the website and extracted. Use the procedure in section 5.3.3.1 through section 5.3.3.4 to download, extract, and install the driver using Windows Vista®, Windows 7®, and XP.

5.3.3.3.1 Download the driver:

1. Locate the Model 648 USB driver on the downloads page on the Lake Shore website.
2. Right-click on the USB driver download link, and select **save target/link as**.
3. Save the driver to a convenient place, and take note as to where the driver was downloaded.

5.3.3.3.2 Extract the driver:

The downloaded driver is in a ZIP compressed archive. The driver must be extracted from this file. Windows® provides built-in support for ZIP archives. If this support is disabled, a third-party application, such as WinZip™ or 7-Zip, must be used.

For Windows Vista® and Windows 7®:

1. Right click on the file and click **extract all**.
2. An Extract Compressed (Zipped) Folders dialog box will appear. It is recommended the default folder is not changed. Take note of this folder location.
3. Click to clear the **Show extracted files when complete** checkbox, and click **Extract**.

For Windows® XP

1. Right-click on the file and click **extract all**.
2. The Extraction wizard will appear. Click **Next**.
3. It is recommended to keep the same default folder. Take note of this folder location and click **Next**.
4. An “Extraction complete” message will be displayed. Click to clear the **Show extracted files** checkbox, and click **Finish**.

5.3.3.3 Manually install the driver

Manually installing drivers differ between versions of Windows®. The following sections describe how to manually install the driver using Windows Vista® and XP. To install the driver you must be logged into a user account that has administrator privileges.

For Windows Vista® and Windows 7®

1. Connect the USB cable from the Model 648 to the computer.
2. Turn on the Model 648.
3. If the Found New Hardware wizard appears, click **Ask me again later**.
4. Open Device Manager. Use this procedure to open Device Manager.
 - a. Click the Windows® **Start** button and type Device Manager in the **Start Search** box.
 - b. Click on the Device Manager link in the Search Results Under Programs dialog box.
 - c. If User Account Control is enabled click **Continue** on the User Account Control prompt.
5. Click **View** and ensure the **Devices by Type** check box is selected.
6. In the main window of Device Manager, locate **Other Devices** in the list of device types. In many instances this will be between Network adapters and Ports (COM & LPT). If the **Other Devices** item is not already expanded, click the + icon. Lake Shore Model 648 should appear indented underneath **Other Devices**. If it is not displayed as Lake Shore Model 648, it might be displayed as USB Device. If neither are displayed, click **Action** and then **Scan for hardware changes**, which may open the Found New Hardware wizard automatically. If the Found New Hardware wizard opens, click **Cancel**.
7. Right-click on Lake Shore Model 648 and click **Update Driver Software**.
8. Click **Browse my computer for driver software**.
9. Click **Browse** and select the location of the extracted driver.
10. Ensure the **Include subfolders** check box is selected and click **Next**.
11. When the driver finishes installing a confirmation message stating “Windows has successfully updated your driver software” should appear. Click **Close** to complete the installation.

For Windows® XP

1. Connect the USB cable from the Model 648 to the computer.
2. Turn on the Model 648.
3. The Found New Hardware wizard should appear. If the Found New Hardware wizard does not appear, the following procedure can be used to open the Hardware Update wizard which can be used instead:
 - a. Open Device Manager. Use this procedure to open the Device Manager:

- Right-click on **My Computer** and then click **Properties**. This will open the System Properties dialog.
 - Click the **Hardware** tab and then click **Device Manager**.
 - b. Click **View** and ensure the **Devices by Type** check box is selected.
 - c. In the main window of Device Manager, locate the **Ports (COM & LPT)** device type. In many instances this will be between the Network adapters and Processors items. If the **Ports (COM & LPT)** item is not already expanded, click the + icon. Lake Shore Model 648 should appear indented underneath **Ports (COM & LPT)**. If it is not displayed as Lake Shore Model 648, it might be displayed as USB Device. If neither are displayed, click **Action** and then select **Scan for hardware changes**, which may open the Found New Hardware wizard automatically. If the Found New Hardware wizard opens, continue to step 4.
 - d. Right-click on Lake Shore Model 648 and click **Update Driver**.
- 4. Select **No, not at this time** and click **Next**.
- 5. Select **Search for the best driver in these locations**, click to clear the **Search removable media (floppy, CD-ROM...)** check box, and click the **Include this location in the search** check box.
- 6. Click **Browse** and open the location of the extracted driver.
- 7. Click **Next**.
- 8. When the driver finishes installing a confirmation message stating “The wizard has finished installing the software for Lake Shore Model 648 electromagnet power supply” should appear. Click **Finish** to complete the installation.

5.3.3.4 Installing the USB Driver from the Included CD

The Model 648 USB driver is available on the included CD. The following section describes the process of installing the driver from the CD. To install the driver you must be logged into a user account that has administrator privileges.

For Windows Vista® and Windows 7®

1. Insert the CD into the computer.
2. Follow steps 1–9 of the Windows Vista® procedure in section 5.3.3.3.
3. Click **Browse** and select the drive containing the included CD.
4. Ensure the **Include subfolders** check box is selected and click **Next**.
5. When the driver finishes installing a confirmation message stating “Windows has successfully updated your driver software” should appear. Click **Close** to complete the installation.

For Windows® XP

1. Insert the CD into the computer.
2. Connect the USB cable from the Model 648 to the computer.
3. Turn on the Model 648.
4. When the Found New Hardware wizard appears select **No, not at this time** and click **Next**.
5. Select **Install the software automatically (recommended)** and click **Next**.
6. The Found New Hardware wizard should automatically search the CD and install the drivers.

When the Found New Hardware Wizard finishes installing the drivers a message stating “the wizard has finished installing the software for Lake Shore Model 648 electromagnet power supply” should appear. Click **Finish** to complete the installation

5.3.4 Communication

Communicating via the USB interface is done using message strings. The message strings should be carefully formulated by the user program according to some simple rules to establish effective message flow control.

5.3.4.1 Character Format

A character is the smallest piece of information that can be transmitted by the interface. Each character is ten bits long and contains data bits, bits for character timing, and an error detection bit. The instrument uses seven bits for data in the American Standard Code for Information Interchange (ASCII) format. One start bit and one stop bit are necessary to synchronize consecutive characters. Parity is a method of error detection. One parity bit configured for odd parity is included in each character.

ASCII letter and number characters are used most often as character data. Punctuation characters are used as delimiters to separate different commands or pieces of data. A special ASCII character, line feed (LF OAH), is used to indicate the end of a message string. This is called the message terminator.

5.3.4.2 Message Strings

A message string is a group of characters assembled to perform an interface function. There are three types of message strings: commands, queries, and responses. The computer issues command and query strings through user programs, the instrument issues responses. Two or more command or query strings can be chained together in one communication, but they must be separated by a semi-colon (;). The total communication string must not exceed 255 characters in length.

A command string is issued by the computer and instructs the instrument to perform a function or change a parameter setting. The format is:

<command mnemonic><space><parameter data><terminators>.

Command mnemonics and parameter data necessary for each one is described in section 5.4. Terminators must be sent with every message string.

A query string is issued by the computer and instructs the instrument to send a response. The query format is:

<query mnemonic><?><space><parameter data><terminators>.

Query mnemonics are often the same as commands with the addition of a question mark. Parameter data is often unnecessary when sending queries. Query mnemonics and parameter data if necessary is described in section 5.4. Terminators must be sent with every message string. The computer should expect a response very soon after a query is sent.

A response string is the instrument's response or answer to a query string. The response can be a reading value, status report or the present value of a parameter. Response data formats are listed along with the associated queries in section 5.4. The response is sent as soon as possible after the instrument receives the query.

5.3.5 Message Flow Control

It is important to remember that the user program is in charge of the USB communication at all times. The instrument cannot initiate communication, determine which device should be transmitting at a given time, or guarantee timing between messages. All of this is the responsibility of the user program.

When issuing commands the user program alone should:

- Properly format and transmit the command including the terminator as 1 string
- Guarantee that no other communication is started for 50 ms after the last character is transmitted

- Not initiate communication more than 20 times/s

When issuing queries or queries and commands together, the user program should:

- Properly format and transmit the query including the terminator as 1 string
- Prepare to receive a response immediately
- Receive the entire response from the instrument including the terminator
- Guarantee that no other communication is started during the response or for 50 ms after it completes
- Not initiate communication more than 20 times/s

Failure to follow these simple rules will result in inability to establish communication with the instrument or intermittent failures in communication.

5.4 Command Summary

This paragraph provides a listing of the IEEE-488 and serial interface commands. A summary of all the commands is provided in TABLE 5-7. All the commands are detailed in section 5.4, which is presented in alphabetical order.

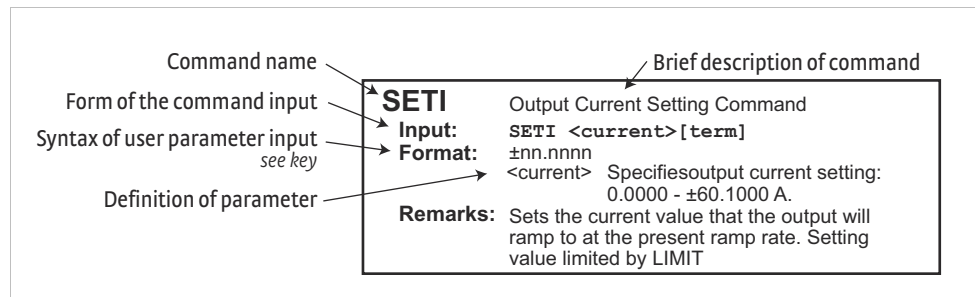

FIGURE 5-8 Sample command format

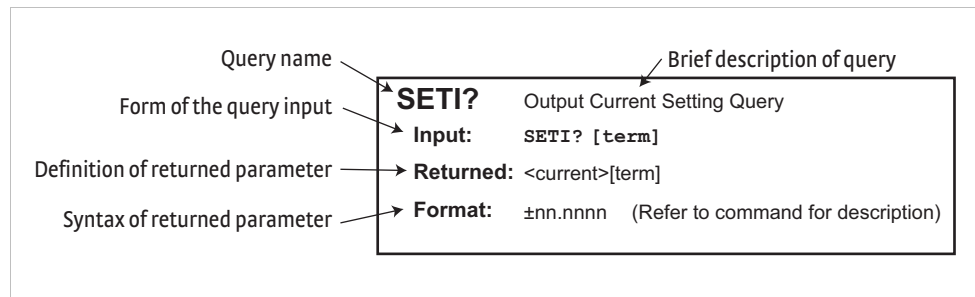

FIGURE 5-9 Sample query format

Q	Begins common interface command
?	Required to identify queries
s[n]	String of alphanumeric characters with length “n.” Send these strings using surrounding quotes. Quotes enable characters such as commas and spaces to be used without the instrument interpreting them as delimiters.
nn...	String of number characters that may include a decimal point.
dd	Dotted decimal format, common with IP addresses. Always contains 4 dot separated 3-digit decimal numbers, such as 192.168.000.012.
[term]	Terminator characters
<...>	Indicated a parameter field, many are command specific.
<state>	Parameter field with only On/Off or Enable/Disable states.
<value>	Floating point values have varying resolution depending on the type of command or query issued.

TABLE 5-6 Interface commands key

Command	Function	Page	Command	Function	Page
QCLS	Clear Interface Cmd	61	LIMIT	Limit Output Settings Cmd	65
QESE	Event Status Enable Register Cmd	61	LIMIT?	Limit Output Settings Query	65
QESE?	Event Status Enable Register Query	61	LOCK	Keyboard Lock Cmd	65
QESR?	Standard Event Status Register Query	61	LOCK?	Keyboard Lock Query	65
QIDN?	Identification Query	61	MAGWTR	Magnet Water Mode Cmd	65
QOPC	Operation Complete Cmd	61	MAGWTR?	Magnet Water Mode Query	65
QOPC?	Operation Complete Query	62	MODE	IEEE Interface Mode Cmd	65
QRST	Reset Instrument Cmd	62	MODE?	IEEE Interface Mode Query	66
QSRE	Service Request Enable Register Cmd	62	OPST?	Operational Status Query	66
QSRE?	Service Request Enable Register Query	62	OPSTE	Operational Status Enable Cmd	66
QSTB?	Status Byte Query	62	OPSTE?	Operational Status Enable Query	66
QTST?	Self-Test Query	62	OPSTR?	Operational Status Register Query	66
QWAI	Wait-to-Continue Cmd	62	RATE	Output Current Ramp Rate Setting Cmd	66
DFLT	Factory Defaults Cmd	63	RATE?	Output Current Ramp Rate Setting Query	66
DISP	Display Parameter Cmd	63	RDGI?	Current Output Reading Query	67
DISP?	Display Parameter Query	63	RDGV?	Output Voltage Reading Query	67
ERCL	Error Clear Cmd	63	RSEG	Ramp Segments Enable Cmd	67
ERST?	Error Status Query	63	RSEG?	Ramp Segments Enable Query	67
ERSTE	Error Status Enable Cmd	63	RSEGS	Ramp Segments Parameters Cmd	67
ERSTE?	Error Status Enable Query	63	RSEGS?	Ramp Segments Parameters Query	67
ERSTR?	Error Status Register Query	64	SETI	Output Current Setting Cmd	67
IEEE	IEEE-488 Interface Parameter Cmd	64	SETI?	Output Current Setting Query	68
IEEE?	IEEE-488 Interface Parameter Query	64	STOP	Stop Output Current Ramp Cmd	68
INTWTR	Internal Water Mode Cmd	64	XPGM	External Program Mode Cmd	68
INTWTR?	Internal Water Mode Query	64	XPGM?	External Program Mode Query	68
KEYST?	Keypad Status Query	64			

TABLE 5-7 Command summary

*CLS	Clear Interface Command
Input	*CLS [term]
Remarks	Clears the bits in the Status Byte Register, Standard Event Status Register, and Operation Event Register, and terminates all pending operations. Clears the interface, but not the instrument. The related instrument command is *RST.
*ESE	Standard Event Status Enable Register Command
Input	*ESE <bit weighting> [term]
Format	nnn
Remarks	The Standard Event Status Enable Register determines which bits in the Standard Event Status Register will set the summary bit in the Status Byte. This command programs the enable register using a decimal value that corresponds to the binary-weighted sum of all bits in the register. Refer to section 5.2.5.1.
*ESE?	Standard Event Status Enable Register Query
Input	*ESE? [term]
Returned	<bit weighting>[term]
Format	nnn (Refer to command for description)
*ESR?	Standard Event Status Register Query
Input	*ESR? [term]
Returned	<bit weighting>
Format	nnn
Remarks	Bits in this register correspond to various system events and latch when the event occurs. When an event bit is set, subsequent events corresponding to that bit are ignored. Set bits remain latched until the register is reset by this query or a *CLS command. Refer to section 5.2.5.1.
*IDN?	Identification Query
Input	*IDN? [term]
Returned	<manufacturer>,<model>,<serial>,<firmware version>[term]
Format	aaaa,aaaaaaaa,aaaaaaa,n.n/n.n
	<manufacture> Manufacturer ID
	<model> Instrument model number
	<serial> Serial number
	<firmware version> Instrument firmware version, main firmware/DAC firmware
Example	LSCI,MODEL648,1234567,1.0/1.0
*OPC	Operation Complete Command
Input	*OPC [term]
Remarks	Used in conjunction with bit 0 (OPC of the Standard Event Status Register. If sent as the last command in a command sequence, bit 0 will be set when the instrument completes the operation that was initiated by the command sequence. Refer to section 5.2.5.1 for more information.

*OPC?	Operation Complete Query
Returned	*OPC? [term] 1[term]
Remarks	Has no interaction with bit 0 (OPC) of the Standard Event Status Register. If sent at the end of a command sequence, the bus will be held until the instrument completes the operation that was initiated by the command sequence. Once the sequence is complete a 1 will be placed in the output buffer. Refer to section 5.2.5.1 for more information.
*RST	Reset Instrument Command
Input	*RST [term]
Remarks	Sets controller parameters to power-up settings. Use the DFLT command to set factory defaults.
*SRE	Service Request Enable Register Command
Input	*SRE <bit weighting> [term]
Format	nnn
Remarks	The Service Request Enable Register determines which summary bits of the Status Byte may set bit 6 (RQS/MSS) of the Status Byte to generate a Service Request. This command programs the enable register using a decimal value that corresponds to the binary-weighted sum of all bits in the register. Refer to section 5.2.7.2.
*SRE?	Service Request Enable Register Query
Input	*SRE? [term]
Returned	<bit weighting>[term]
Format	nnn (Refer to command for description)
*STB?	Status Byte Query
Input	*STB? [term]
Returned	<bit weighting>[term]
Format	nnn
Remarks	This command is similar to a Serial Poll except it is processed like any other instrument command. It returns the same result as a Serial Poll except that the Status Byte bit 6 (RQS/MSS) is not cleared. Refer to section 5.2.5.2.
*TST?	Self-Test Query
Input	*TST? [term]
Returned	<status>[term]
Format	n
Remarks	<status> 0 = no errors found, 1 = errors found The Model 648 reports status based on test done at power up.
*WAI	Wait-to-Continue Command
Input	*WAI [term]
Remarks	This command is not supported in the Model 648.

DFLT	Factory Defaults Command
Input	DFLT 99 [term]
Remarks	Sets all configuration values to factory defaults and resets the instrument. The instrument must be at zero amps for this command to work. The "99" is included to prevent accidentally setting the unit to defaults.
DISP	Display Parameter Command
Input	DISP<brightness> [term]
Format	n
	<brightness> Specifies display brightness: 0=25%, 1=50%, 2=75%, 3=100%
DISP?	Display Parameter Query
Input	DISP? [term]
Returned	<brightness>[term]
Format	n (Refer to command for definition)
ERCL	Error Clear Command
Input	ERCL [term]
Remarks	This command will clear the operational errors. The errors will only be cleared if the error conditions have been removed. Hardware errors can never be cleared. Refer to section 5.2.6.1 for a list of error bits.
ERST?	Error Status Query
Input	ERST? [term]
Returned	<hardware errors>, <operational errors>[term]
Format	nnn,nnn
Remarks	The integers returned represent the sum of the bit weighting of the error bits. Refer to section 5.2.6.1 and section 5.2.6.2 for a list of error bits. Use the ERCL command to clear the operational errors. Hardware errors cannot be cleared.
ERSTE	Error Status Enable Command
Input	ERSTE<hardware errors>, <operational errors>[term]
Format	nnn,nnn
Remarks	Each bit has a bit weighting and represents the enable/disable mask of the corresponding error bits in the Error Status Register. This determines which status bits can set the corresponding summary bits in the Status Byte Register. To enable an error bit, send the command ERSTE with the sum of the bit weighting for each desired bit. Refer to section 5.2.6.1 and section 5.2.6.2 for a list of error bits.
ERSTE?	Error Status Enable Query
Input	ERSTE? [term]
Returned	<hardware errors>, <operational errors>[term]
Format	nnn,nnn (Refer to section 5.2.6.1 and section 5.2.6.2 for a list of error bits)

ERSTR?	Error Status Register Query
Input	ERSTR? [<i>term</i>]
Returned	<hardware errors>, <operational errors>[<i>term</i>]
Format	nnn,nnn
Remarks	The integers returned represent the sum of the bit weighting of the error bits. These error bits are latched when an error condition is detected. This register is cleared when it is read. Refer to section 5.2.6.1 and section 5.2.6.2 for a list of error bits. Use the ERRCL command to clear the operational errors. Hardware errors cannot be cleared.
<hr/>	
IEEE	IEEE-488 Interface Parameter Command
Input	IEEE <terminator>, <EOI enable>, <address> [<i>term</i>]
Format	n,n,nn
	<terminator> Specifies the terminator. Valid entries: 0 = <CR><LF>, 1 = <LF><CR>, 2 = <LF>, 3 = no terminator (must have EOI enabled)
	<EOI enable> Sets EOI mode: 0 = Enabled, 1 = Disabled
	<address> Specifies the IEEE address: 1 through 30. (Address 0 and 31 are reserved.)
Example	IEEE 0,0, 4[term] —after receipt of the current terminator, the instrument uses <CR><LF> as the new terminator, uses EOI mode, and responds to address 4.
<hr/>	
IEEE?	IEEE-488 Interface Parameter Query
Input	IEEE? [<i>term</i>]
Returned	<terminator>, <EOI enable>, <address>[<i>term</i>]
Format	n,n,nn (refer to command for description)
	<mode> 0 = Manual Off, 1 = Manual On, 2 = Auto, 3 = Disabled
<hr/>	
INTWTR	Internal Water Mode Command
Input	INTWTR <mode> [<i>term</i>]
Format	n
	<mode> 0 = Manual Off, 1 = Manual On, 2 = Auto, 3 = Disabled.
Example	INTWTR 2[term] —Places the internal water mode to Auto, which will automatically control the power supply water valve based on the internal power dissipation and temperature.
<hr/>	
INTWTR?	Internal Water Mode Query
Input	INTWTR? [<i>term</i>]
Returned	<mode>[<i>term</i>]
Format	n (Refer to command for description)
<hr/>	
KEYST?	Keypad Status Query
Input	KEYST? [<i>term</i>]
Format	nn
Returned	<code>[<i>term</i>]
Remarks	Returns a number descriptor of the last key pressed since the last KEYST?. Returns “01” after initial power-up. Returns “00” if no key is pressed since last query.

LIMIT	Limit Output Settings Command
Input	LIMIT <current>,<rate> [term]
Format	+nnn.nnn,+nn.nnnn <current> Specifies the maximum output current setting allowed: 0 A through 135.100 A. <rate> Specifies the maximum output current ramp rate setting allowed: 0.0001 A/s through 50.000 A/s.
Remarks	Sets the upper setting limits for output current, compliance voltage, and output current ramp rate. This is a software limit that will limit the settings to these maximum values.
LIMIT?	Limit Output Settings Query
Input	LIMIT? [term]
Returned	<current>,<rate>[term]
Format	+nnn.nnn,+nn.nnnn (refer to command for description)
LOCK	Keyboard Lock Command
Input	LOCK <state>,<code> [term]
Format	n,nnn <state> 0 = Unlock, 1 = Lock All, 2 = Lock Limits <code> Specifies lock-out code. Valid entries are 000–999.
Remarks	Locks out all front panel entry operations.
Example	LOCK 1,123 [term]—enables keypad lock and sets the code to 123.
LOCK?	Keyboard Lock Query
Input	LOCK? [term]
Returned	<state>,<code>[term]
Format	n,nnn (refer to command for description)
MAGWTR	Magnet Water Mode Command
Input	MAGWTR <mode> [term]
Format	n <mode> 0 = Manual Off, 1 = Manual On, 2 = Auto, 3 = Disabled
Example	MAGWTR 2 [term]—places the magnet water mode to Auto, which will automatically control the magnet water valve based on the calculated output power.
MAGWTR?	Magnet Water Mode Query
Input	MAGWTR? [term]
Returned	<mode>[term]
Format	n (refer to command for description)
MODE	IEEE Interface Mode Command
Input	MODE <mode> [term]
Format	n <mode> 0 = local, 1 = remote, 2 = remote with local lockout.
Example	MODE 2 [term]—places the Model 648 into remote mode with local lockout.

MODE?	IEEE Interface Mode Query
Input	MODE? [term]
Returned	<mode>[term]
Format	n (refer to command for description)
<hr/>	
OPST?	Operational Status Query
Input	OPST? [term]
Returned	<bit weighting> [term]
Format	nnn
Remarks	The integer returned represents the sum of the bit weighting of the operational status bits. Refer to section 5.2.6.2 for a list of operational status bits.
<hr/>	
OPSTE	Operational Status Enable Command
Input	OPSTE <bit weighting> [term]
Format	nnn
Remarks	Each bit has a bit weighting and represents the enable/disable mask of the corresponding operational status bit in the Operational Status Register. This determines which status bits can set the corresponding summary bit in the Status Byte Register. To enable a status bit, send the command OPSTE with the sum of the bit weighting for each desired bit. Refer to section 5.2.6.2 for a list of operational status bits.
<hr/>	
OPSTE?	Operational Status Enable Query
Input	OPSTE? [term]
Returned	<bit weighting> [term]
Format	nnn (Refer to section 5.2.6.2 for a list of operational status bits)
<hr/>	
OPSTR?	Operational Status Register Query
Input	OPSTR? [term]
Returned	<bit weighting> [term]
Format	nnn
Remarks	The integers returned represent the sum of the bit weighting of the operational status bits. These status bits are latched when the condition is detected. This register is cleared when it is read. Refer to section 5.2.6.2 for a list of operational status bits.
<hr/>	
RATE	Output Current Ramp Rate Setting Command
Input	RATE <rate>, [term]
Format	+n.nnnn <rate> Specifies the rate at which the current will ramp at when a new output current setting is entered: 0.0001 A/s through 50.000 A/s.
Remarks	Sets the output current ramp rate. This value will be used in both the positive and negative directions. Setting value is limited by LIMIT.
<hr/>	
RATE?	Output Current Ramp Rate Setting Query
Input	RATE? [term]
Returned	<rate>[term]
Format	+n.nnnn (refer to command for description)

RDGI?	Current Output Reading Query
Input	RDGI? [term]
Returned	<current>[term]
Format	+nn.nnnn <current> Actual measured output current
<hr/>	
RDGV?	Output Voltage Reading Query
Input	RDGV? [term]
Returned	<voltage>[term]
Format	+n.nnnn <voltage> Actual output voltage measured at the power supply terminals.
<hr/>	
RSEG	Ramp Segments Enable Command
Input	RSEG <enable> [term]
Format	n[term] <enable> Specifies if ramp segments are to be used: 0=Disabled, 1=Enabled.
Remarks	Ramp segments are used to change the output current ramp rate based on the output current. Ramp segments need to be setup first using the RSEGS command.
<hr/>	
RSEG?	Ramp Segments Enable Query
Input	RSEG? [term]
Returned	<enable>[term]
Format	n (refer to command for description)
<hr/>	
RSEGS	Ramp Segments Parameters Command
Input	RSEGS <segment>, <current>, <rate> [term]
Format	n, +nnn.nnn, +n.nnnn [term] <segment> Specifies the ramp segment to be modified: 1 to 5 <current> Specifies the upper output current setting that will use this segment: 0.0000-+135.100 A. <rate> Specifies the rate at which the current will ramp at when the output current is in this segment: 0.0001 to 50.000 A/s.
Remarks	Ramp segments are used to change the output current ramp rate based on the output current. The ramp segment feature needs to be turned on using the RSEG command.
<hr/>	
RSEGS?	Ramp Segments Parameters Query
Input	RSEGS? <segment> [term]
Returned	<current>, <rate>[term]
Format	+nnn.nnn, +n.nnnn (refer to command for description)
<hr/>	
SETI	Output Current Setting Command
Input	SETI <current> [term]
Format	±nnn.nnn <current> Specifies the output current setting: 0.000 - ±135.100 A.
Remarks	Sets the current value that the output will ramp to at the present ramp rate. The setting value is limited by LIMIT.

SETI?	Output Current Setting Query
Input	SETI? [term]
Returned	<current>[term]
Format	±nnn.nnn (refer to command for description)

STOP	Stop Output Current Ramp Command
Input	STOP [term]
Remarks	This command will stop the output current ramp within 2 s of sending the command. To restart the ramp, use the SETI command to set a new output current setpoint.

XPGM	External Program Mode Command
Input	XPGM<mode> [term]
Format	n <mode> 0=Internal, 1=External, 2=Sum
Example	XPGM 1[term]: places the Model 648 into external program mode where the output current is set by an external voltage.

XPGM?	External Program Mode Query
Input	XPGM? [term]
Returned	<mode>[term]
Format	n (refer to command for description)

Chapter 6: Service

6.1 General

This chapter provides basic service information for the Model 648 electromagnet power supply. Customer service of the product is limited to the information presented in this chapter. Factory trained service personnel should be consulted if the instrument requires repair.

6.2 USB Troubleshooting

This section provides USB interface troubleshooting for issues that arise with new installations, existing installations, and intermittent lockups.

6.2.1 New Installation

1. Check that the instruments interface is set to USB.
2. Check that the USB driver is installed properly and that the device is functioning. In Microsoft Windows®, the device status can be checked using Device Manager by right-clicking **Lake Shore Model 648 electromagnet power supply** under **Ports (COM & LPT)** or **Other Devices** and then clicking **Properties**. Refer to section 5.3.3 for details on installing the USB driver.
3. Check that the correct com port is being used. In Microsoft Windows®, the com port number can be checked using Device Manager under **Ports (COM & LPT)**.
4. Check that the correct settings are being used for communication. Refer to section 5.3.3 for details on installing the USB driver.
5. Check cable connections and length.
6. Send the message terminator.
7. Send the entire message string at one time including the terminator. (Many terminal emulation programs do not.)
8. Send only one simple command at a time until communication is established.
9. Be sure to spell commands correctly and use proper syntax.

6.2.2 Existing Installation No Longer Working

1. Power the instrument off, then on again to see if it is a soft failure.
2. Power the computer off, then on again to see if communication port is locked up.
3. Check all cable connections.
4. Check that the com port assignment has not been changed. In Microsoft Windows®, the com port number can be checked using Device Manager under **Ports (COM & LPT)**.
5. Check that the USB driver is installed properly and that the device is functioning. In Microsoft Windows®, the device status can be checked using Device Manager by right-clicking **Lake Shore Model 648 electromagnet power supply** under **Ports (COM & LPT)** or **Other Devices** and then clicking **Properties**.

6.2.3 Intermittent Lockups

1. Check cable connections and length.
2. Increase the delay between all commands to 100 ms to make sure the instrument is not being overloaded.
3. Ensure that the USB cable is not unplugged and that the Model 648 is not powered down while the com port is open. The USB driver creates a com port when the USB connection is detected, and removes the com port when the USB connection is no longer detected. Removing the com port while in use by software can cause the software to lock up or crash.

6.3 IEEE Interface Troubleshooting

This section provides IEEE interface troubleshooting for issues that arise with new installations, old installations, and intermittent lockups.

6.3.1 New Installation

1. Check the instrument address.
2. Always send a message terminator.
3. Send the entire message string at one time including the terminator.
4. Send only one simple command at a time until communication is established.
5. Be sure to spell commands correctly and use proper syntax.
6. Attempt both Talk and Listen functions. If one works but not the other, the hardware connection is working, so look at syntax, terminator, and command format.

6.3.2 Existing Installation No Longer Working

1. Power the instrument off, then on again to see if it is a soft failure.
2. Power the computer off then on again to see if the IEEE card is locked up.
3. Verify that the address has not been changed on the instrument during a memory reset.
4. Check all cable connections.

6.3.3 Intermittent Lockups

1. Check cable connections and length.
2. Increase the delay between all commands to 50 ms to make sure the instrument is not being overloaded

6.4 Fuse Drawer

The fuse drawer supplied with the Model 648 holds the instrument line fuses and line voltage selection module. The drawer holds two 10.30 mm × 38 mm (0.41 in × 1.5 in) time delay fuses. It requires two good fuses of the same rating to operate safely. Refer to section 6.7 for instructions to exchange fuses.



FIGURE 6-1 Fuse drawer

6.5 Line Voltage Selection

The Model 648 may be configured for seven basic AC power configurations: 200 VAC, 208 VAC, 220 VAC, 230 VAC, 380 VAC, 400 VAC, and 415 VAC. Proper voltage selection must be made before connection to the power mains. Each configuration requires the appropriate wiring within the power wiring access panel on the rear of the instrument. Nominal line voltages and appropriate selections are shown in TABLE 6-1. Refer to section 3.4.1 for further details. See FIGURE 6-2 for general locations.

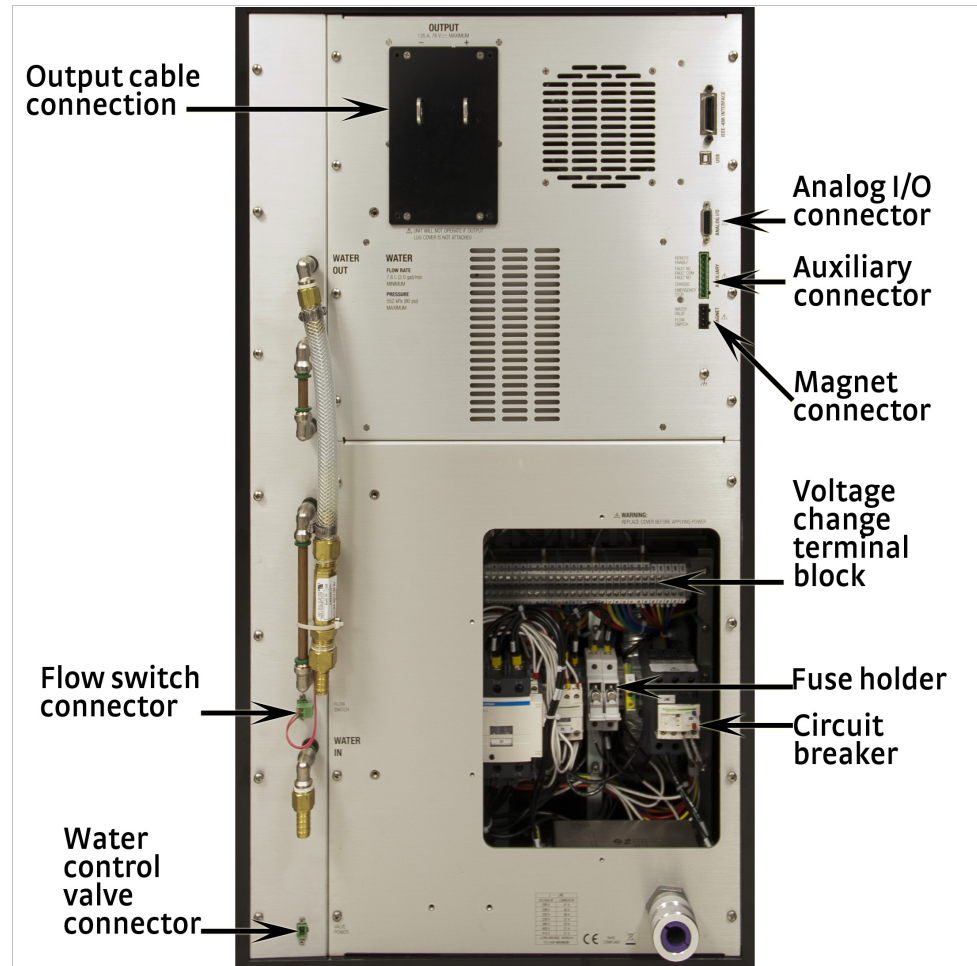

FIGURE 6-2 Model 648 rear panel: Left: Bottom half (shown with wiring cover removed); Right: Top half

Use the following procedure to change the instrument line voltage.

WARNING

To avoid potentially lethal shocks, turn off the power supply and disconnect it from AC power before performing this procedure.

1. Identify the power wiring access panel on the rear of the Model 648.
2. Remove the perimeter screws holding the power wiring access panel.
3. Observe the four voltage-selection wires held by the clear plastic wiring guide. (FIGURE 6-3).
4. Loosen the screw terminals presently holding the four wires.
5. Relocate the four wires (using the wiring guide) to the desired voltage position. Use TABLE 6-1 to determine the correct voltage position.
6. Place the wires into the appropriate screw terminals and tighten.
7. Verify solid, tight screw connections to these four wires.
8. Replace the power wiring access panel using all perimeter screws.
9. Verify the voltage indicator in the window of the power wiring access panel.

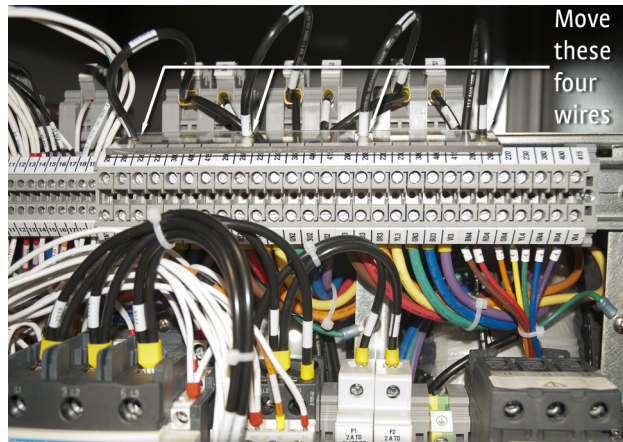

FIGURE 6-3 Voltage change detail

6.6 Circuit Breaker Setting

The main three-phase input power is protected by an automatic-reset circuit breaker within the instrument. A smaller, start-up power supply is fused separately and discussed in section 6.7. If the breaker trips, it will reset within a few minutes and the unit can be restarted. If the unit trips again after a short time, the circuit breaker trip current may be set incorrectly. TABLE 6-1 shows required voltage and current settings.

Voltage tap	Circuit breaker
200 V	50 A
208 V	50 A
220 V	46 A
230 V	46 A
380 V	37 A
400 V	37 A
415 V	37 A

TABLE 6-1 Voltage and current selection

! WARNING

To avoid potentially lethal shocks, turn off the power supply and disconnect it from AC power before performing this procedure. For continued protection against fire hazard, use only the recommended current setting for the line voltage selected.

Use this procedure to verify or change the circuit breaker current setting.

1. Turn the front panel line power switch off.
2. Remove the main power from the Model 648 using the disconnect switch.
3. Identify the power wiring access panel on the rear of the Model 648.
4. Remove the perimeter screws holding the power wiring access panel.
5. Refer to FIGURE 6-2 to locate the fuse detailed in FIGURE 6-5.

- Lift the circuit breaker access door and visually confirm the setting as shown in FIGURE 6-4.



FIGURE 6-4 Circuit breaker

- If the setting is incorrect, use a small straight blade screwdriver to rest it according to TABLE 6-1.
- Close the circuit breaker access door.
- Replace the power wiring access panel using all perimeter screws.

6.7 Power Line Fuse Replacement

The Model 648 uses a low-power, start-up power supply to provide power to the main contactor coil through multiple thermal safety switches. The start-up supply is energized any time the three-phase power input voltage is connected to the Model 648. This section deals with the fuses for this supply. If the power line fuses for this supply are open, the Model 648 internal three-phase contactor will not close and normal operation will not be possible. Access to these fuses is through the power wiring access panel.

WARNING

To avoid potentially lethal shocks, turn off the power supply and disconnect it from AC power before performing this procedure.

CAUTION

For continued protection against fire hazard, replace only with the same fuse type and rating specified for the line voltage selected.

Use this procedure to change the power line fuses.

- Identify the power wiring access panel on the rear of the Model 648.
- Turn the front panel line power switch off.
- Remove mains power from the Model 648 fusing the disconnect switch.
- Remove the perimeter screws holding the power wiring access panel.
- Locate the two fuse holder assemblies as shown in FIGURE 6-2 and in FIGURE 6-5.
- Pull open the access door to remove a fuse.
- Check the fuse for continuity. Replace fuse(s) if necessary. Fuses should be replaced in pairs. Fuses are inserted small-end first as shown (FIGURE 6-5).
- Close the fuse access door(s).
- Replace the wiring access panel using all perimeter screws.

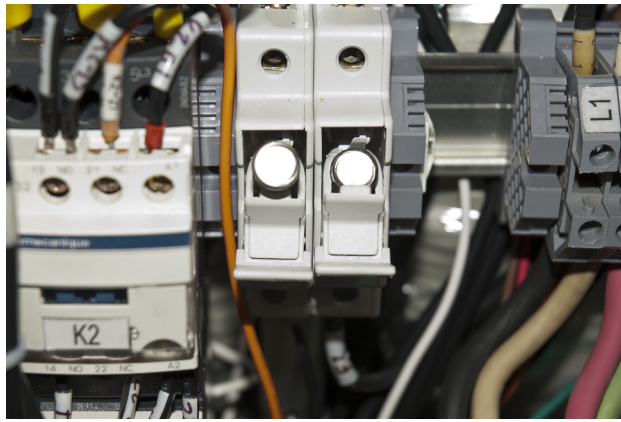

FIGURE 6-5 Fuse drawer

6.8 Factory Reset Menu

It is sometimes necessary to reset instrument parameter values or clear the contents of curve memory. Both are stored in nonvolatile memory called NOVRAM, but they can be cleared individually. Instrument calibration is not affected except for room temperature calibration, which should be recalibrated after parameters are set to default values or any time the thermocouple curve is changed.

6.8.1 Default Values

The factory defaults can be reset, and the user curves cleared, using the Factory Reset menu. To access the Factory Reset menu, press and hold the **Escape** key for 5 s. Once the menu appears, set either Reset to Defaults or Clear Curves, or both, to Yes, then highlight Execute and press **Enter**.

Output settings	Output current*	0 A
	Current ramp rate	50.000 A/s
Maximum settings	Max output current	135.1 A
	Max ramp rate	50.000 A/s
External program mode	External program mode	Internal
Ramp segments	Ramp segments	Disabled
	Ramp segments current	0 A
	Ramp segments rate	1.0000 A/s
Display	Brightness	25%
Keypad locking	State	Unlocked
	Lock code	123
Computer interface	Baud	57,600
	IEEE-488 address	12
	IEEE-488 terminators	CR/LF
	Mode*	Local
Water settings	Magnet water	Disabled
	Internal water	Disabled

*Indicates value is also initialized on power up

TABLE 6-10 Default parameter values

6.9 Error Messages

Error messages appear on the lower part of the instrument display when it identifies a problem during operation. The Fault LED will light in conjunction with the error message. Press **Status** to see a more extensive description of the error message. If the error condition can be immediately cleared, you can do so by pressing **Status** while in the error status display. Refer to section 4.15 for a description of the error status display.

6.9.1 Types of Error Messages

There are three types of error messages. Their descriptions are defined here and in TABLE 6-2 and TABLE 6-3.

- *Instrument hardware errors* are related to internal instrument circuitry. When one of these errors occurs, the Fault LED is solidly lit, the output setting is set to 0 A, current entry will not be allowed and there is no way to clear the error unless power is cycled. If one of these error messages persists after power is cycled, the instrument requires repair. Instrument Hardware Errors are listed in TABLE 6-2.
- *Operational errors* are related to instrument operation and do not necessarily indicate a hardware problem. When one of these errors occurs, the Fault LED will be blinking and the error condition can be cleared once the fault condition has been removed. Operational errors are listed in TABLE 6-3.
- *User errors* are related to user requests that cannot be processed. These errors generate responses that immediately explain the cause of the error. These are usually simple order-of-operation issues and are easily resolved. The fault LED is not used for these simpler errors. User errors are self-explanatory and are therefore not listed.

Internal temperature fault	Cold plate temperature is over 45° C. The output setting is set to 0 A and no current entry will be allowed. The error message will flash for 10 s, and then the Model 648 will turn itself off.
Output over voltage	The output voltage is greater than the 76 V compliance voltage limit, indicating a problem with the compliance voltage circuitry. The output setting is set to 0 A and no current entry will be allowed. The error message will flash for 10 s, and then the Model 648 will turn itself off.
Output over current	The measured output current exceeded 140 A. The output setting is set to 0 A and no current entry will be allowed. The error message will flash for 10 s, and then the Model 648 will turn itself off.
DAC processor not responding	The processor that controls the output DAC is not responding or is responding incorrectly. The output setting is set to 0 A and no current entry will be allowed. Cycle power to attempt to clear.
Output control failure	One of the internally monitored voltages is beyond an acceptable range on power up. The output setting is set to 0 A and no current entry will be allowed. Cycle power to clear attempt to clear.
Output stage protect	One or more of the power MOSFETs used to drive the output is in a latchup condition. This could have been externally generated (ESD or a short at the output terminals) or it could have been internally generated. The output setting is set to 0 A and no current entry will be allowed. Cycle power to attempt to clear this error.

TABLE 6-2 *Instrument hardware errors*

Remote enable fault detected	The remote enable connection loop is not closed. The output setting is set to 0 A and no current entry will be allowed. Once the loop is closed, press Status or send “ERCL” over the computer interface to clear the error.
Power supply flow switch fault detected	The power supply flow switch connection loop is not closed. The output setting is set to 0 A and no current entry will be allowed. Once the loop is closed, press Status or send “ERCL” over the computer interface to clear the error.
Magnet flow switch fault detected	The magnet flow switch connection loop is not closed. The output setting is set to 0 A and no current entry will be allowed. Once the loop is closed, press Status or send “ERCL” over the computer interface to clear the error.
High line voltage detected	The output stage voltage (Out Stg V) is greater than 85 V. The most likely cause is a power main voltage that is too high. This error will clear when the power main voltage is within specified tolerances. Continued operation is allowed, but may not be optimal.
Low line voltage detected	The output stage voltage (Out Stg V) is less than 75 V. The most likely cause is a power main voltage that is too low. This error will clear when the power mains voltage is within specified tolerances. Continued operation is allowed, but may not be optimal.
Internal temperature high	Cold plate temperature is over 40° C. The output setting is set to 0 A and no current entry will be allowed. The error will clear when the cold plate temperature falls below 40° C. This may indicate low cooling water flow or high water temperature.
External current program error	The instrument was not allowed to change to external or sum current programming modes (including power-up) because the programming voltage was greater than 0.025 V. This error can be cleared when the programming voltage is less than 0.025 V or the instrument is changed to internal current programming mode.
Calibration invalid	The instrument has either not been calibrated or calibration data has been corrupted. Press both ESC and Enter simultaneously to clear the error at any time. The instrument can still be used in this state but there is no guarantee that it is operating within specifications. The instrument must be recalibrated to properly correct this error condition.

TABLE 6-3 *Operational errors*

6.10 Calibration Procedure

Instrument calibration can be obtained through Lake Shore Service. Refer to section 6.12 for technical inquiries and contact information.

6.11 Connector and Cable Definitions

All non-power electrical connections to the rear of the Model 648 are detailed in this section.

6.11.1 Analog I/O Connector

The analog I/O connector provides the connections for the external programming voltage as well as analog representations of the current and voltage output levels. Although these inputs/outputs are electronically balanced to minimize ground loops, the common-mode voltage should not exceed 5 V on the outputs and 2 V on the input.

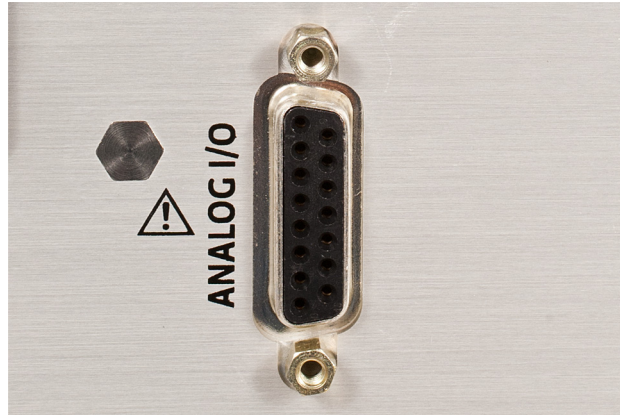

FIGURE 6-6 Analog I/O connector

Pin	Name	Pin	Name
1	NC	9	NC
2	Chassis-common	10	Chassis-common
3	Current program —	11	Current program +
4	Chassis-common	12	Chassis-common
5	Voltage monitor —	13	Voltage monitor +
6	Chassis-common	14	Chassis-common
7	Current monitor —	15	Current monitor +
8	Chassis-common		

TABLE 6-4 Model 648 analog/output connector

6.11.2 Magnet Water Connector

The magnet water connector provides the means to connect a water control valve (24 VAC) and an associated water flow switch (closed during flow) to protect the magnet from loss of water flow. Pins 1 & 2 must be closed for normal operation. Pins 3 & 4 supply 24 VAC at 1 A for operation of a water control valve. See TABLE 6-5 for the magnet connector details.

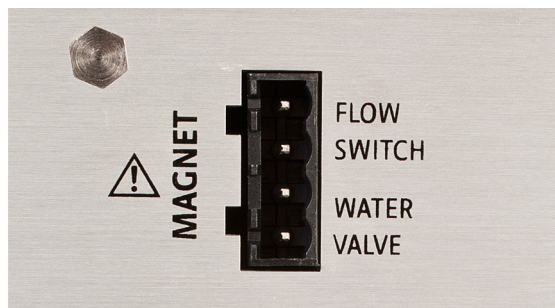

FIGURE 6-7 Magnet water connector

Pin	Name
1	Flow switch (com)
2	Flow switch
3	Magnet water valve A
4	Magnet water valve B

TABLE 6-5 Magnet connector details

6.11.3 Auxiliary Connector

The auxiliary connector provides connections for three functions:

- Emergency stop: this normally-closed circuit turns off power to the Model 648 just as if the Off (O) button was pressed on the front panel when opened. Normal operation requires a closed connection between the pins.
- Fault relay: the fault relay can be used to communicate the presence of a Model 648 fault to external equipment. The relay follows the operation of the fault light on the front panel. Both normally-open and normally-closed configurations are provided. The fault contact name represents the state of the contact in a powered off/fault condition. For example, the normally closed (NC) fault contact will be closed during a power off/fault condition, and open during normal operation. The contacts are electrically isolated from the Model 648 chassis.
- Remote enable: these contacts are similar in function to the flow switch inputs. Normal (enabled) operation requires a closed connection between the pins.

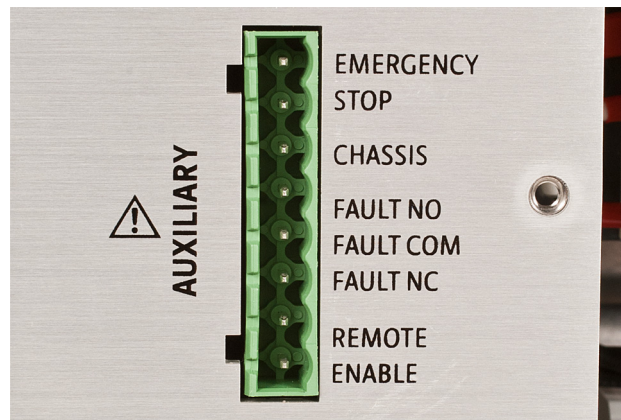

FIGURE 6-8 Auxiliary connector

Pin	Name
1	Emergency stop A
2	Emergency stop B
3	Chassis-common
4	Fault-NO
5	Fault-COM
6	Fault-NC
7	Chassis-common

TABLE 6-6 Auxiliary connector details

6.11.4 Power Supply Water Connectors

This section describes the flow switch and the water control valve.

6.11.4.1 Flow Switch

The flow switch connector provides the means to connect the mandatory water flow switch (closed during flow) to protect the Model 648 from loss of water flow. When water is flowing, pins 1 and 2 will be closed, allowing normal operation.

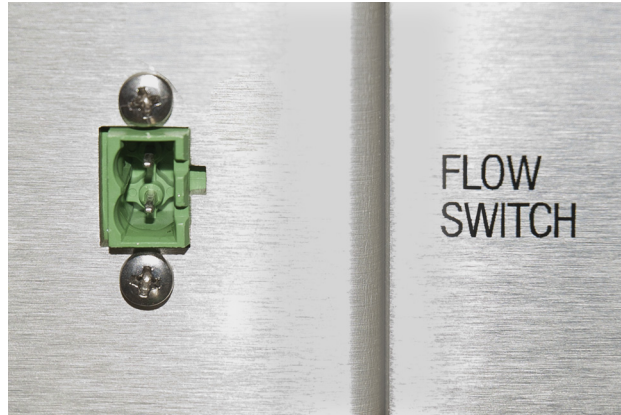

FIGURE 6-9 Flow switch connector

Pin	Name
1	Flow switch (com)
2	Flow switch

TABLE 6-7 Power supply water flow switch connector details

6.11.4.2 Water Control Valve

The water control valve connector provides the means to connect a water control valve. Pins 1 and 2 supply 24 VAC at 1 A for operation of a water control valve.



FIGURE 6-10 Water control valve connector

Pin	Name
1	Power supply (water valve A)
2	Power supply (water valve B)

TABLE 6-8 Power supply water control valve connector details

6.11.5 USB Connector

This connector provides one of two means of computer interface. Command descriptions are found in Chapter 5.

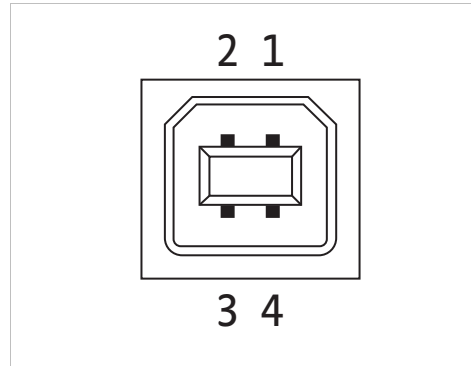

FIGURE 6-11 USB pin and connector details

Pin	Name	Description
1	VCC	+5 VDC
2	D-	Data -
3	D+	Data +
4	GND	Ground

TABLE 6-9 USB pin and connector details

6.12 Technical Inquiries

Refer to the following sections when contacting Lake Shore for application assistance or product service. Questions regarding product applications, price, availability and shipments should be directed to sales. Questions regarding instrument calibration or repair should be directed to instrument service. Do not return a product to Lake Shore without a Return Material Authorization (RMA) number (section 6.12.2).

6.12.1 Contacting Lake Shore

The Lake Shore Service Department is staffed Monday through Friday between the hours of 8:00 AM and 5:00 PM EST, excluding holidays and company shut down days.

Contact Lake Shore Service through any of the means listed below. However, the most direct and efficient means of contacting is to complete the online service request form at <http://www.lakeshore.com/sup/serf.html>. Provide a detailed description of the problem and the required contact information. You will receive a response within 24 hours or the next business day in the event of weekends or holidays.

If you wish to contact Service or Sales by mail or telephone, use the following:

Mailing address	Lake Shore Cryotronics Instrument Service Department 575 McCorkle Blvd. Westerville, Ohio USA 43082-8888	
E-mail address	sales@lakeshore.com service@lakeshore.com	Sales Instrument Service
Telephone	614-891-2244 614-891-2243 select the Service option	Sales Instrument Service
Fax	614-818-1600 614-818-1609	Sales Instrument Service
Web service request	http://www.lakeshore.com/sup/serf.html	Instrument Service

TABLE 6-10 Contact information

6.12.2 Return of Equipment

The electromagnet power supply is packaged to protect it during shipment.



The user should retain any shipping carton(s) in which equipment is originally received, in the event that any equipment needs to be returned.

If original packaging is not available, a minimum of 76.2 mm (3 in) of shock adsorbent packing material should be placed snugly on all sides of the instrument in a sturdy wooden crate. Please use reasonable care when removing the electromagnet power supply from its protective packaging and inspect it carefully for damage. If it shows any sign of damage, please file a claim with the carrier immediately. Do not destroy the shipping container; it will be required by the carrier as evidence to support claims. Call Lake Shore for return and repair instructions.

All equipment returns must be approved by a member of the Lake Shore Service Department. The service engineer will use the information provided in the service request form and will issue an RMA. This number is necessary for all returned equipment. It must be clearly indicated on both the shipping carton(s) and any correspondence relating to the shipment. Once the RMA has been approved, you will receive appropriate documents and instructions for shipping the equipment to Lake Shore.

6.12.3 RMA Valid Period

RMAs are valid for 60 days from issuance; however, we suggest that equipment needing repair be shipped to Lake Shore within 30 days after the RMA has been issued. You will be contacted if we do not receive the equipment within 30 days after the RMA is issued. The RMA will be cancelled if we do not receive the equipment after 60 days.

6.12.4 Shipping Charges

All shipments to Lake Shore are to be made prepaid by the customer. Equipment serviced under warranty will be returned prepaid by Lake Shore. Equipment serviced out-of-warranty will be returned FOB Lake Shore.

6.12.5 Restocking Fee

Lake Shore reserves the right to charge a restocking fee for items returned for exchange or reimbursement.