



User's Manual

Model DTC-500

Cryogenic Temperature Indicator/Controller

Obsolete Notice:

This manual describes an obsolete Lake Shore product. This manual is a copy from our archives and may not exactly match your instrument. Lake Shore assumes no responsibility for this manual matching your exact hardware revision or operational procedures. Lake Shore is not responsible for any repairs made to the instrument based on information from this manual.



Lake Shore Cryotronics, Inc.
575 McCorkle Blvd.
Westerville, Ohio 43082-8888 USA

Internet Addresses:
sales@lakeshore.com
service@lakeshore.com

Visit Our Website:
www.lakeshore.com

Fax: (614) 891-1392
Telephone: (614) 891-2243

Methods and apparatus disclosed and described herein have been developed solely on company funds of Lake Shore Cryotronics, Inc. No government or other contractual support or relationship whatsoever has existed which in any way affects or mitigates proprietary rights of Lake Shore Cryotronics, Inc. in these developments. Methods and apparatus disclosed herein may be subject to U.S. Patents existing or applied for. Lake Shore Cryotronics, Inc. reserves the right to add, improve, modify, or withdraw functions, design modifications, or products at any time without notice. Lake Shore shall not be liable for errors contained herein or for incidental or consequential damages in connection with furnishing, performance, or use of this material.

Table of Contents

Section	Page
I. General Information	
1.1 Introduction	1
1.2 Description	1
1.3 General Specifications	2
1.4 Major Assemblies Supplied	3
1.5 Accessory Equipment and Custom Options	3
II. Installation	
2.1 Introduction	5
2.2 Initial Inspection	5
2.3 Power Requirements	5
2.4 Grounding Requirements	5
2.5 Installation	7
2.6 Repackaging for Shipment	7
III. Operation Instructions	
3.1 Introduction	9
3.2 Controls, Indicators and Connectors	9
3.3 Initial Checks	13
3.4 Temperature Readout Mode	13
3.5 Constant Temperature Control Mode	16
3.6 Manual Reset Heating Mode	17
3.7 Temperature Readout Mode (Sensor B)	17
3.8 Remote Temperature Programming	18
3.9 Grounding	21
IV. Theory of Operation	
4.1 Introduction	22
4.2 Detailed Description	22
(a) Regulated Power Supplied	25
(b) Diode Constant Current Supply	25
(c) Set Point Voltage Supply and Divider	25
(d) Variable Gain Amplifier	26
(e) Automatic Reset Circuit, Bounding Circuit	27
(f) Output Power Amplifier	27
(g) Manual Heater Current Control	27
(h) Heater Current Metering and Limiting	28
V. Maintenance and Trouble Shooting	
5.1 Introduction	29
5.2 Test Equipment and Accessories	29
5.3 General Remarks	29
5.4 Servicing Printed Circuit Boards	30
5.5 Operational Checks	30
5.6 Normal Operating Voltages and Gains	31
5.7 Calibration of Set Point Voltage	32
5.8 Calibration of Sensor Current	32
5.9 Parts List, Printed Circuit Board Component Locator and Schematic	33
VI. Appendixes	40



FIGURE 1.1 MODEL DTC-500
CRYOGENIC TEMPERATURE INDICATOR CONTROLLER

SECTION I

General Information

1.1 Introduction

This section contains a description of the Model DTC-500 Cryogenic Temperature Controller, its applications, general specifications, major assemblies supplied and accessory equipment available.

1.2 Description and Applications

The Model DTC-500 Cryogenic Temperature Controller is housed in an aluminum case with standard 19" relay panel front for rack mounting. All connections are at the rear of the case with all normal operating controls on the front panel. The instrument is line operated from either 115 volt or 230 volt mains, 50 or 60 hertz.

The controller is designed to accept a voltage signal from a temperature sensitive transducer (generally a DT-500 or TG-100 Diode which is not supplied), compare this signal with an internal set point voltage, amplify and process their difference (error signal), and drive an external heating element. An internal precision 10 microampere constant current source is provided to excite the temperature transducer.

The error processing section of the controller is of the proportional plus integral mode design. Generous amplifier gain ranges have been provided to affect rapid closed loop response times, low steady state temperature offsets and to insure system stability over a wide range of thermal system parameters.

The output power amplifier is capable of supplying up to 10 Watts of heater power. In view of the high cost of some cryogenic fluids such as helium, cost consciousness suggests that cryostat design and operating strategies be planned to limit heater power requirements to substantially less than ten watts. **Power boosters** are available from the company as accessory equipment if required for special applications.

The principal intended application of the DTC-500 Controller is as a constant temperature regulator for laboratory size cryostats. Its basic design, however, enables it to be used as a general purpose controller for sensors whose raw outputs range between 0 and 3.0 volts and whose incremental sensitivities are in the range of tenths of millivolts.

In addition to its use as a closed loop automatic temperature controller, the Model DTC-500 Controller may be used as a precision thermometer. By adjusting the set point voltage so that the error signal is zero, the output voltage of the temperature sensor is accurately obtained. Reference to a voltage versus temperature calibration curve for the transducer in use will then give its temperature.

1.3 General Specifications

The following specifications for the DTC-500 Controller are applicable when used with the TG-100 or DT-500 full range temperature sensitive diode.

General:

Controller Range	- 1 ⁰ K to 400 ⁰ K nominal
Heater Output	- 10 ⁻³ to 10 watts, 0-1 Amp, 0-10 Volts
Sensor	- Models TG-100 or DT-500, temperature sensitive diodes, single-ended or floating model
Sensor Input	- four terminal connection, constant current, potentiometric
Sensor Current	- 10 microamperes
Input Line Voltage	- 115V or 220V, 50-60 Hz
Power Consumption	- 30VA
Circuit Design	- Solid State
Weight	- 15 pounds
Dimensions	- 5¼" high, 19" wide, 11½ deep, rack mounting
Gain	- 3 Amps/millivolt into 10 ohm resistor at maximum setting

Temperature Control:

Set Points	- 0 to 3.0 volts Switch - 1 volt per step, 100 mV per step, and 10 turn interpolating potentiometer with 0.1 mV graduations, 0.1% linearity
Repeatability	- ±10 microvolts (0.01 ⁰ K or better)
Automatic Reset	- 3 to 100 second variable time constant, or off

Manual Output Control Range	- 10 turn potentiometer control, 0 to full range current
Heater Current Ranges	- 10 mA, 30mA, 100mA, 300mA, 1A
Heater Resistance for Max Power	- 10 Ohms
Controller Proportional Gain	- 3 Amps/mV in automatic mode (nominal)

Temperature Readout:

(2 Sensor connections, front panel selectable between control sensor and temperature sensing only sensor)

Accuracy	- equivalent to 100 microvolts (0.1°K worse case) ± calibration error of sensor
Excitation Current	- 10 microamperes
Excitation Current Regulation	- 0.05%
Sensor Calibration Chart	- must be supplied by manufacturer of sensor in use.

1.4 Major Assemblies Supplied

The Model DTC-500 Cryogenic Temperature Controller includes as standard equipment, in addition to the controller proper, the following additional components:

- (1) 1, Operating and Service Manual
- (2) 2, Five pin plugs for temperature sensor cables
- (3) 1, Seven pin plug for remote set point cable

Temperature sensitive diodes are not supplied as part of the DTC-500 Controller.

1.5 Accessory Equipment and Custom Options Available

The following accessory equipment and custom options are available from the factory. Items marked with an asterisk (*) are of a custom nature. The customer should discuss these items with a factory representative before ordering.

- (1) Extra 5 and 7 pin connectors.

- (2) Multisensor selector panel. (Special low thermal offset switch and cabling for selecting among multiple sensors)*
- (3) Remote set point voltage control and programming module.*
- (4) Custom modification of sensor current supply value.*
- (5) TG-100 Gallium Arsenide or DT-500 Temperature Sensitive Diode (Uncalibrated). (See data sheets at end of this manual for nominal operating characteristics and case styles available.)
- (6) TG-100 Gallium Arsenide or DT-500 Temperature Sensitive Diode, (Calibrated) Standards laboratory calibration service for correlating diode output voltage with diode temperature. See sensors data sheet for additional information.
- (7) Power Boosters for heater power requirements in excess of ten watts, or other than ten ohm heater resistances.

SECTION II

Installation

2.1 Introduction

This section contains information and instructions necessary for the installation and shipping of the Model DTC-500 Cryogenic Temperature Controller. Included are initial inspection instructions, power and grounding requirements, installation information and instructions for repackaging for shipment.

2.2 Initial Inspection

This instrument was electrically and mechanically inspected prior to shipment. It should be free from marks and scratches, and in perfect working order upon receipt. To confirm this, the instrument should be inspected visually for obvious damage upon receipt and tested electrically by use to detect any concealed damage. Be sure to inventory all components supplied before discarding any shipping materials. If there is damage to the instrument in transit, be sure to file appropriate claims with the carrier, and/or insurance company. Please advise the company of such filings. In case of parts shortages please advise the company. The standard Lake Shore Cryotronics warranty is given on page ii.

2.3 Power Requirements

Before connecting the power cable to the line, ascertain that the line voltage selector switch (115V or 230V) is in the appropriate position for the line voltage to be used. Examine the power line fuse, FU1, (Key No 13, Page 11) to insure that it is appropriate for the line voltage. (115V = 1.0 Amp, 230V = 0.4 Amp) Nominal permissible line voltage fluctuation is $\pm 10\%$ at 50 to 60 Hz.

Caution: Disconnect line cord before inspecting or changing line fuse.

2.4 Grounding Requirements

To protect operating personnel, the National Electrical Manufacturers' Association (NEMA) recommends and some local codes require instrument panels and cabinets to be grounded. This instrument is equipped with a three-conductor power cable which, when plugged into an appropriate receptacle, grounds the instrument.

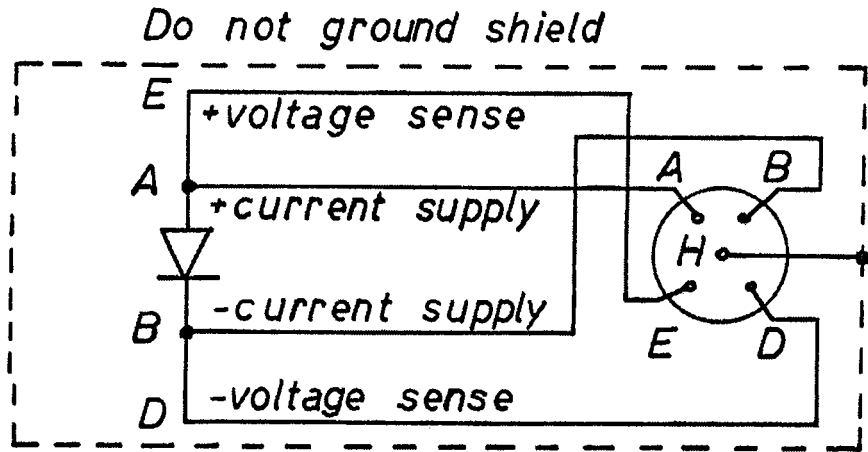

(A) RECOMMENDED SENSOR CABLE

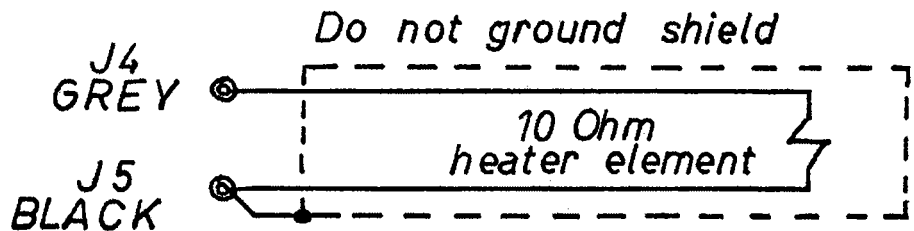

(B) RECOMMENDED HEATER CABLE

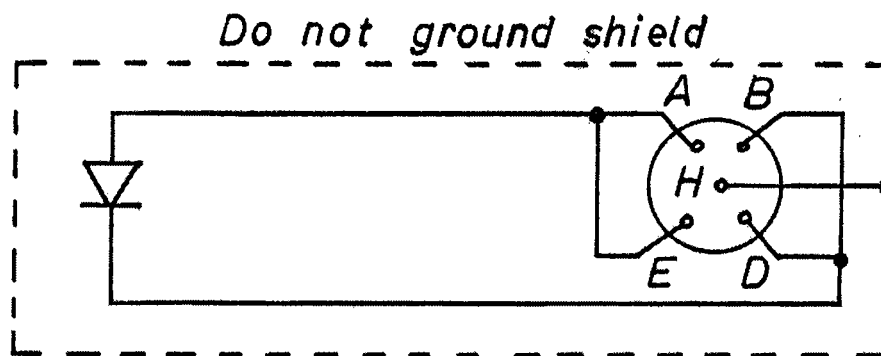

(C) ALTERNATE SENSOR CABLE

FIGURE 2.1 SENSOR AND HEATER CABLES

2.5 Installation

The DTC-500 Controller is all solid state and does not generate significant heat. It may therefore be rack mounted in close proximity to other equipment in dead air spaces. However, the heat from such adjacent equipment should not subject the DTC-500 Controller to an ambient temperature in excess of 50°C (122°F). As with any precision instrument, it should not be subjected to the shock and vibrations which usually accompany high vacuum pumping systems.

The recommended cable diagrams for the sensor diode and heater element are given in Figure 2.1 (a) and (b). The use of a four wire diode connection is highly recommended to avoid introducing lead IR drops in the voltage sensing pair. The indicated shielding connections are the recommended standard practice to avoid ground loops. If thermal considerations dictate, the alternate wiring scheme shown in Fig. 2.1 (c) may be used for the diode.

The heating element should be floated to preclude the possibility of any of the heater current being conducted into the diode sensor leads. Electrical feedback in addition to the desired thermal feedback, may cause oscillations and certainly erroneous temperature readings.

Inspect the heater element fuse FU2, (Key No. 15, Pg. 11) for proper value. (3 AG, 1.0A, Slow Blow, or smaller current rating if desired.) This fuse protects the output amplifier from damage in case of heater element shorting. Use of a larger fuse may cause damage to the instrument and invalidates the instrument warranty.

2.6 Repackaging for Shipment

Before returning an instrument to the factory for repair, please discuss the malfunction with a factory representative. He may be able to suggest several field tests which will preclude returning a satisfactory instrument to the factory when the malfunction is elsewhere. If it is indicated that the fault is in the instrument after these tests, the representative will send shipping instructions and labels for returning it.

When returning an instrument, please attach a tag securely to the instrument itself (not on the shipping carton) clearly stating:

- (1) Owner and address
- (2) Instrument Model and Serial Number
- (3) Malfunction symptoms
- (4) Description of external connections and cryostats.

If the original carton is available, repack the instrument in plastic bag, place in carton using original spacers to protect protruding controls, and close carton. Seal lid with paper or nylon tape. Affix mailing labels and "FRAGILE" warnings.

If the original carton is not available, wrap the instrument in water proof paper or plastic wrapping material before placing in an inner container. Place shock absorbing material around all sides of the instrument to prevent damage to protruding controls. Place the inner container in a second heavy carton and seal with tape. Affix mailing labels and "FRAGILE" warnings.

SECTION III

Operating Instructions

3.1 Introduction

This section contains a description of the operating controls, their adjustment under normal operating conditions, typical controller applications and suggested cryostat adjustment techniques. These instructions are predicated upon the instrument having been installed as outlined in Section II. The diode polarity as shown in Fig. 2.1 (a) in particular must be correct. A calibrated diode is assumed to be connected, as shown in Fig. 2.1 (a), to the "Sensor A" receptacle and a 10 ohm heating element is assumed to be connected to the "Heater" terminals as shown in Fig. 2.1 (b).

3.2 Controls, Indicators and Connectors

The operating controls, indicators and connectors on the instrument's front and rear panels are shown in Figures 3.1 and 3.2. The numbers with leaders to various controls in the figures are keyed to the entries in Table 3.1.

Table 3.1

NO. KEY	NAME	FUNCTION
1	SET POINT - VOLTS 0 - 0.1	Ten turn vernier interpolator potentiometer to continuously adjust set point voltage between switch setting and next higher setting.
2	SET POINT - VOLTS 0, 1 and 2 VOLTS	Kelvin-Varley divider, selects most significant digits of setpoint voltage.
3	SET POINT - VOLTS 0 to .9 VOLTS	Selector switch of Kelvin Varley divider 0.1 volt per step
4	GAIN 1 - 100	Adjusts overall controller gain between 330 and 33,000. (Figure 3.3)
5	AUTO-RESET OFF, MIN. - MAX.	Adjusts gain of amplifier following integrator. (See Fig. 3.3) Effectively determines time constant of integrator between 3 and 100 seconds.
6	AUTO A, MAN. A, MAN. B.	Mode selector switch: AUTO A uses sensor A to automatically control temperature. MAN. A disengages automatic control feature but permits readout of sensor A voltage. MAN. B permits readout of sensor B voltage.

Table 3.1 (cont.)

NO. KEY	NAME	FUNCTION
7	MAN. RESET	When mode selector switch (5) is in either MAN. A or MAN. B position, the MAN. RESET ten turn potentiometer permits the user to manually adjust the current to the heater element. (Caution: High settings will quickly boil away cryogenic fluids).
8	MAX. HEATER-AMP.	Switch selected current limiter. Use of a low setting will avoid inadvertent boil-off in setting up system.
9	POWER	A. C. line switch (ON/OFF)
10	NO LABEL	A. C. line pilot light
11	HEATER CURRENT	Meters heater element current. Full scale deflection corresponds to MAX. HEATER . switch () setting.
12	NULL	Indicates the difference between the set point voltage and the sensor output voltage. Meter is non-linear for large errors of either sign.
13	115/230V 50-60 Hz	A. C. line voltage selector slide switch
14	¼A S. B.	A. C. line fuse (FU1). See para. 2.3
15	NO LABEL	A. C. line cord
16	1.0A, S. B.	Heater element line fuse, 1 AMP., Slow Blow
17	SENSOR A	Sensor A cable receptacle. (Five pin, Amphenol type 126-217 Plug)
18	SENSOR B	Sensor B cable receptacle. (Five pin, Amphenol type 126-217 Plug)
19	TEMP. SET POINT INTERNAL, REMOTE	Selects between internal set point voltage divider and external divider for comparison with sensor voltage. Front panel set point controls in-operative when switch is in the "REMOTE" position. Be sure this control is set on "INTERNAL" since its location on the rear panel may cause one to overlook its setting when initially checking out the instrument.

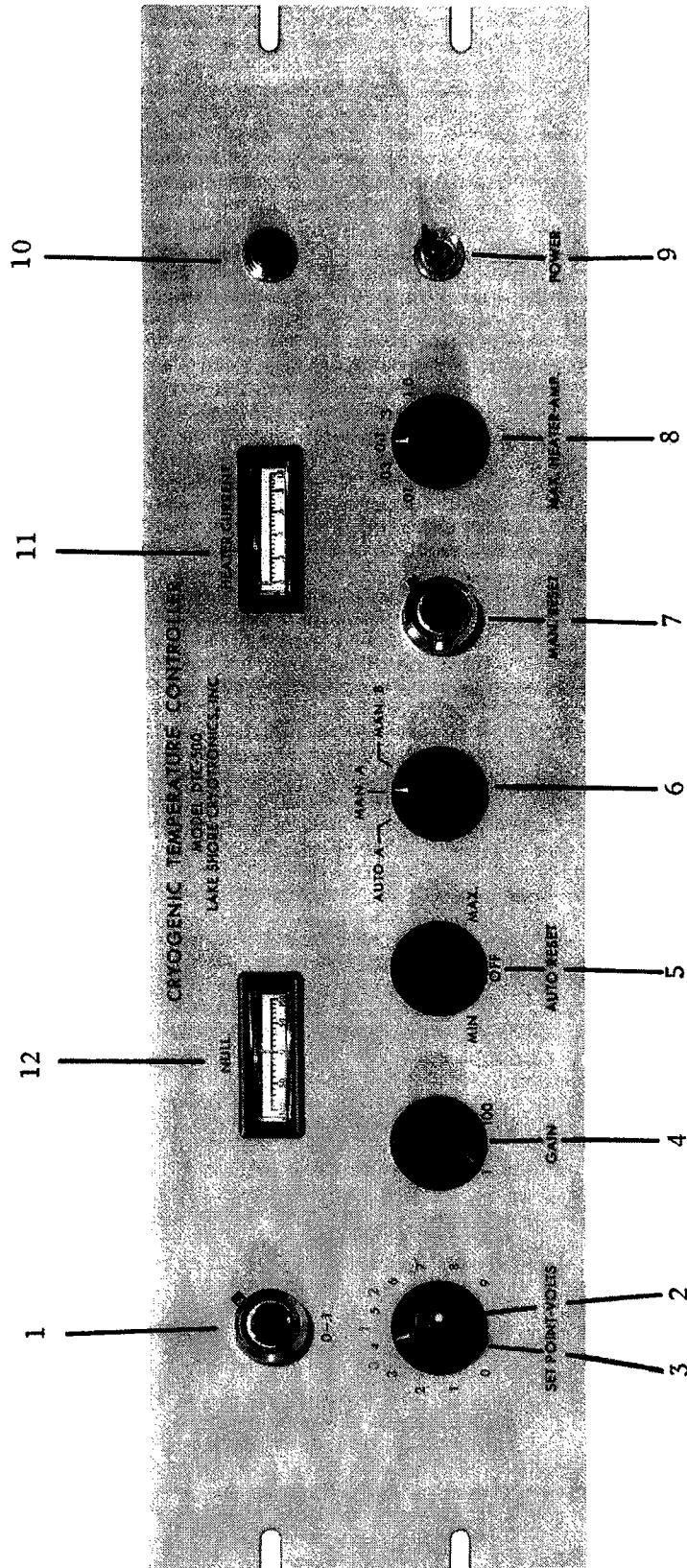

FIGURE 3.1 FRONT PANEL

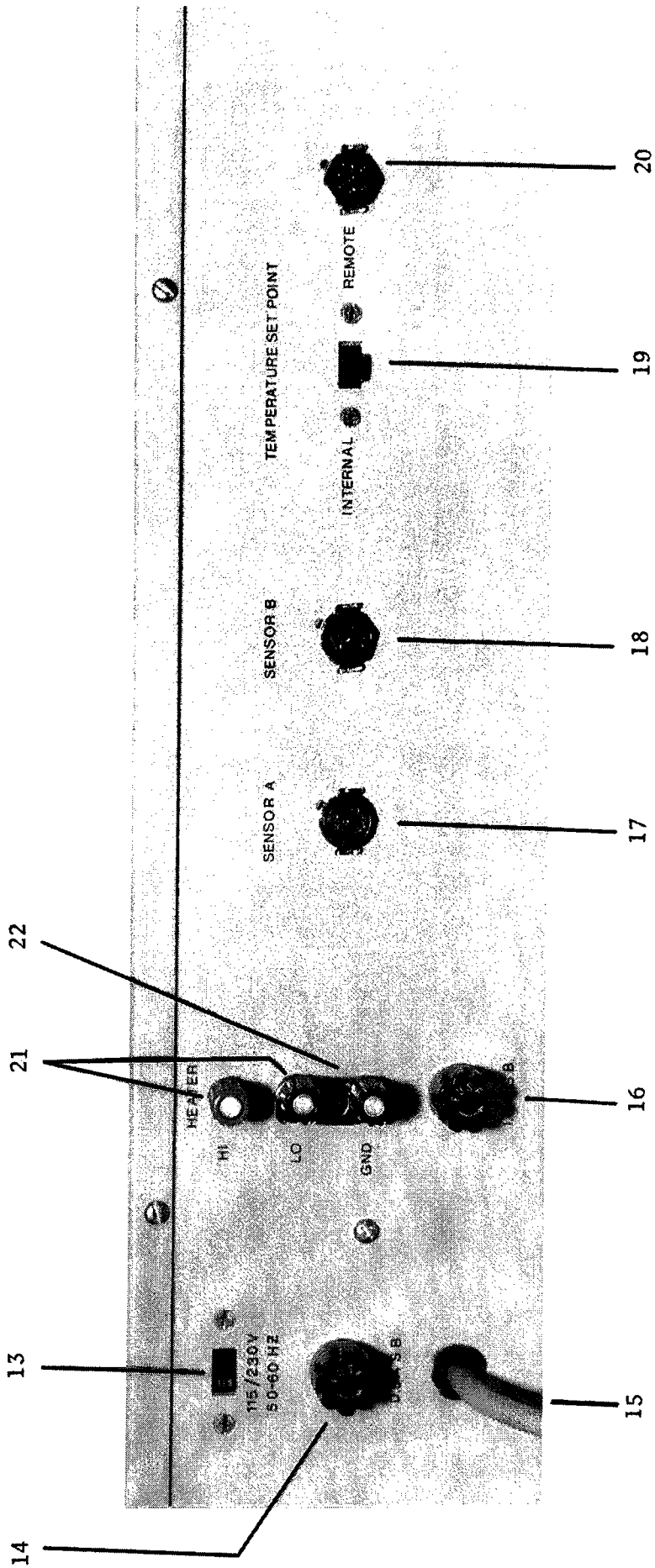

FIGURE 3.2 REAR PANEL

Table 3.1 (cont.)

NO. KEY	NAME	FUNCTION
20	NO LABEL	Remote set point voltage divider cable receptacle (Amphenol 126-195 plug).
21	HEATER	Heater element lead terminals (Grey is the high side and Black is the low side).
22	GROUND	Chassis ground terminal

3.3 Initial Checks

Initial checks, calibration checks, and servicing procedures are described in Section V, MAINTENANCE.

3.4 Temperature Readout Mode

To use the DTC-500 as a cryogenic thermometer to measure the temperature of a calibrated diode connected to SENSOR A terminals, initially position switches and controls as follows:

- (1) Temperature set point switch (Key No. 19) to "INTERNAL".
- (2) Mode switch (Key No. 6) to "MAN. A".
- (3) "MAN. RESET" (Key No. 7) to zero.
- (4) "MAX. HEATER-AMP." (Key No. 8) to 0.01.
- (5) "GAIN" (Key No. 4) to minimum setting.
- (6) "AUTO RESET" (Key No. 5) to off.
- (7) "POWER" switch (Key No. 9) to on.

The null meter will probably deflect off scale (either left or right) when the power switch is turned on. If the deflection is to the left, the set point voltage is less than the sensor voltage. If the deflection is to the right, the set point voltage is greater than the sensor voltage.

Adjust the set point voltage until the "NULL" meter is centered while increasing the "GAIN" towards maximum. Increasing the voltage will move the meter pointer to the right; decreasing the set point voltage will deflect the meter pointer to the left. After centering the meter, read the set point voltage by adding the vernier potentiometer reading (approximately scaled) to the "SET POINT" switch setting value. The ten turn dial's 500 divisions correspond to 100 millivolts, so that each dial division corresponds to 0.2 millivolts, readable to 0.1 millivolt.

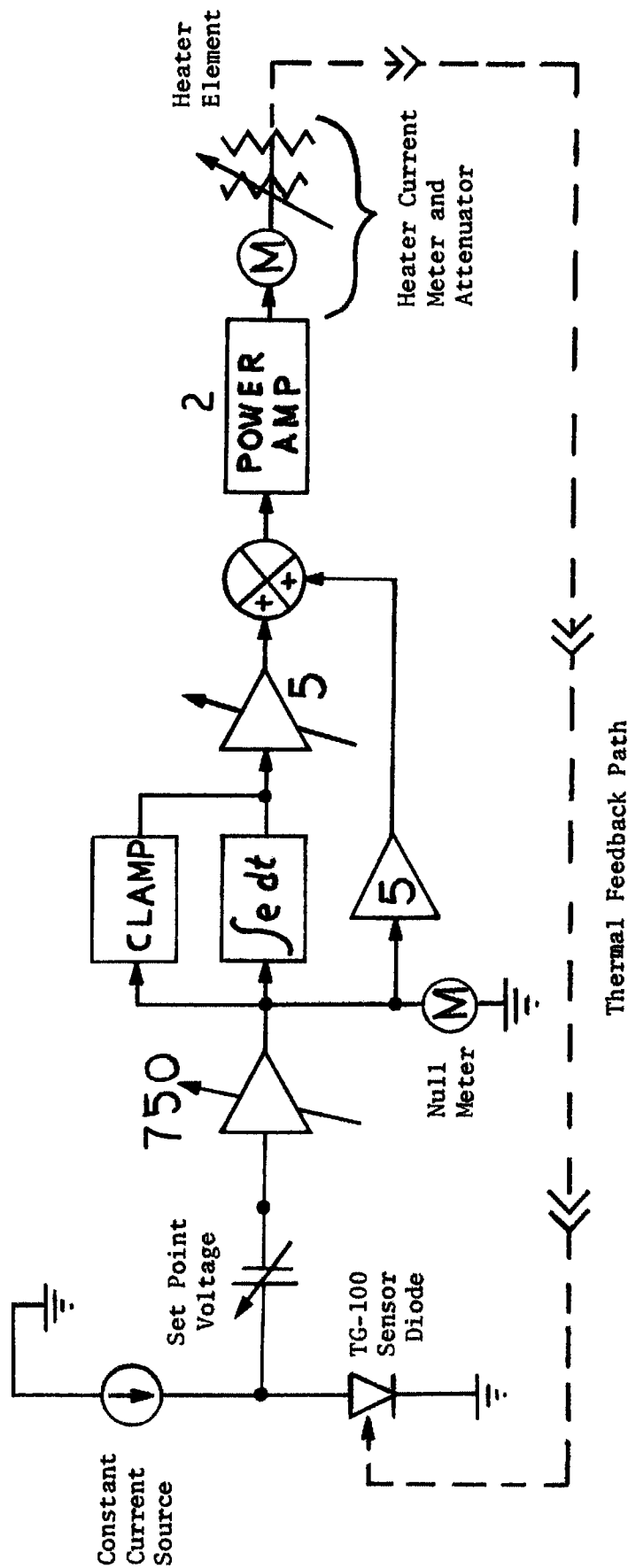

FIGURE 3.3-BLOCK DIAGRAM, DTC-500 TEMPERATURE CONTROLLER

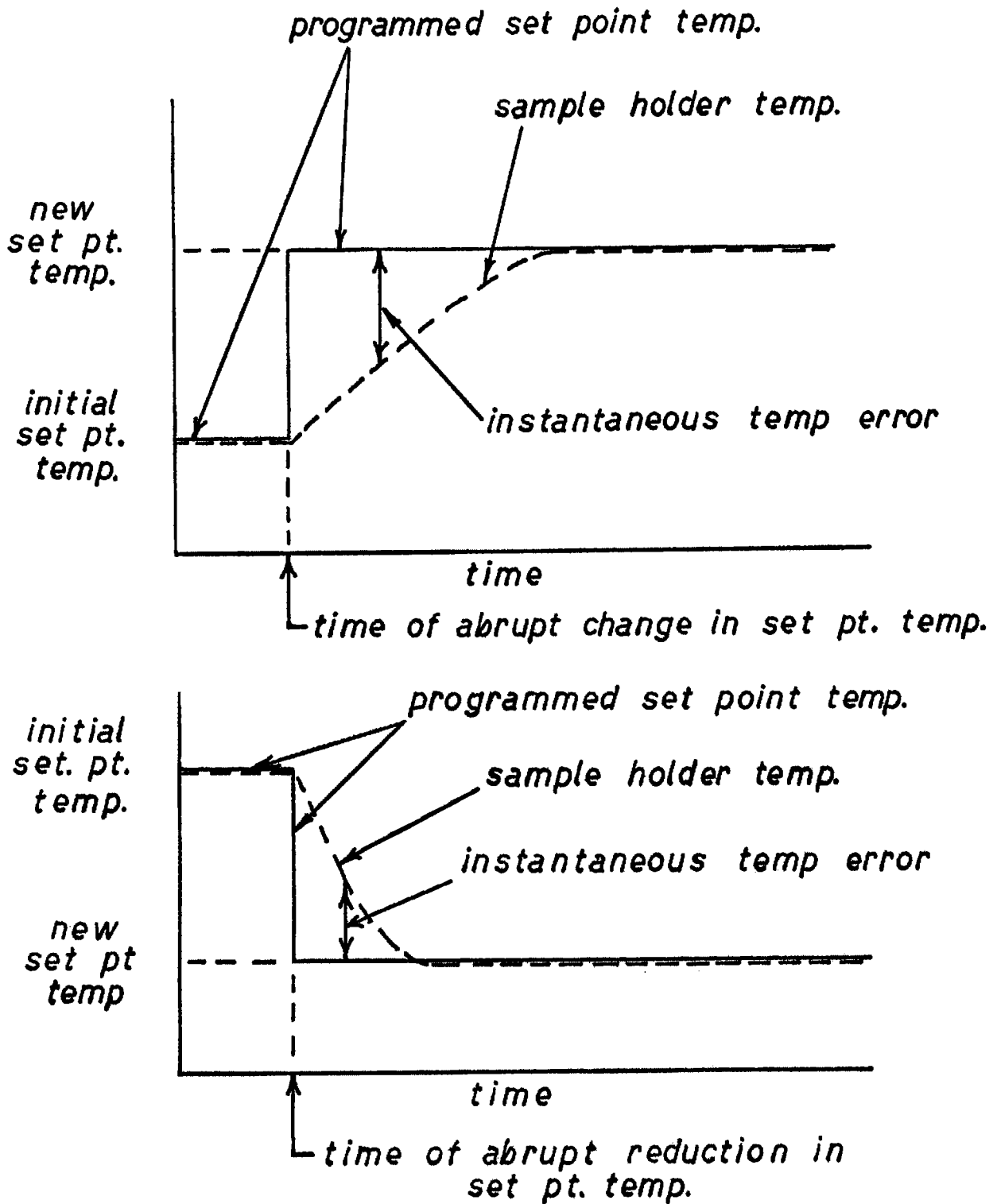

FIGURE 3.4 TEMPERATURE VERSUS TIME
CHARACTERISTICS OF CONTROLLER

After determining the set point voltage, refer to the diode calibration chart to ascertain the diode temperature.

3.5 Constant Temperature Control Mode

Assume that a calibrated diode is in use as described in paragraph 3.4. To maintain a constant temperature, determine the corresponding set point voltage from the diode calibration chart. Set this voltage on the "SET POINT" switch and vernier.

Position controls as indicated below:

- (1) Temperature set point switch (Key No. 19) to "INTERNAL."
- (2) Mode switch (Key No. 6) to "AUTO A."
- (3) "MAN. RESET" (Key No. 7) to zero.
- (4) "MAX. HEATER-AMP" (Key No. 8) to 1.0 AMP.
- (5) "GAIN" (Key No. 4) to minimum setting.
- (6) "AUTO RESET" (Key No. 5) to off.
- (7) "SET POINT VOLTS" switch and potentiometer to voltage corresponding to desired temperature.
- (8) "POWER" switch (Key No. 9) to on.

If the block or sample holder whose temperature is to be controlled is colder than the set point temperature, the sensor diode voltage will be high and the null meter will deflect to the left. Slowly increase the "GAIN" setting (Key No. 4) in a clockwise direction. The "HEATER CURRENT" meter should show an immediate up scale deflection proportional to the "GAIN" setting. The "NULL" meter should start to come off its full left deflection position as the gain is increased. As the sample holder temperature approaches the set point temperature, the NULL meter will approach center scale and the "HEATER CURRENT" meter will assume a steady value even with a further increase in the gain setting. Continue to increase the gain until an incremental change in gain produces a negligible reduction in the null error, but not so high as to produce oscillations.

To further reduce the null error, rotate the "AUTO RESET" gain control (Key No. 5) out of the detent (off) position in the clockwise direction. As the control is advanced, the null meter should approach the center position with unobservable error. Leave the "AUTO RESET" vernier in the position required to reduce the null error to zero, but below any level which induces oscillations.

As the NULL METER pointer approaches zero, the HEATER CURRENT will increase from zero to the new steady state value required to maintain the sample at the lower temperature requested. The NULL METER should read zero as the HEATER CURRENT stabilizes at its new value.

Now abruptly decrease the set point vernier control by ten units. The NULL meter should deflect to the left and the HEATER CURRENT meter should deflect toward full scale. As the sample holder heats, the NULL meter pointer will tend to zero and the HEATER CURRENT meter reading will decrease toward its new steady state value. As the NULL meter centers, the HEATER CURRENT should stabilize at the new constant value required to maintain the desired temperature.

A sketch of the temperature versus time pattern described above is given in Figure 3.4. Observe that there is no temperature overshoot or oscillation when the "GAIN" and "AUTO RESET" controls are properly adjusted. (This statement presupposes that the sample holder may be accurately modeled as a simple R-C type time constant circuit.)

If oscillation or overshoot are observed when changing the set point voltage in small increments, reduce the GAIN and AUTO RESET settings until oscillations are no longer observed.

3.6 Manual Heating Mode

By placing the mode selector switch (Key No. 6) in either position MAN. A or MAN. B, a constant current may be supplied to the heater element. The magnitude of the current is determined by the setting of the MAN. RESET potentiometer (Key No. 7) and the MAX. HEATER AMP. switch (Key No. 8). The current supplied to the heater is indicated on the HEATER CURRENT meter. The full scale reading of the meter corresponds to the MAX. HEATER AMP switch setting.

3.7 Temperature Readout Mode (Sensor B)

In some applications, the temperature is controlled (or regulated) at one physical location while it is desired to measure the temperature at a second location. This requires two sensors, "Sensor A" located at the temperature control point and "Sensor B" at the second point where only the temperature is to be measured. Sensor B must be calibrated.

Assume that the temperature at Sensor A has been stabilized by operating the controller in the constant temperature control mode as described in Section 3.5. By observing the steady HEATER CURRENT reading, one may switch to the MAN. A mode as described in Section 3.6 and establish this same current by adjusting the MAN RESET potentiometer. By alternating between the AUTO A

and Man A modes, the MAN RESET potentiometer may be trimmed sufficiently accurately to hold the temperature steady in the MAN A position. Then switch to the MAN B position and quickly adjust the SET POINT VOLT switch and potentiometer to zero the NULL meter. This reading is used to determine the temperature of Sensor B. After taking the Sensor B voltage reading, reset the SET POINT VOLT switch and potentiometer to the desired temperature control point and then return to AUTO A control mode.

If there is appreciable null error upon returning to the AUTO A mode of control, the adjustment of the MAN RESET control should be refined and the measurement of the Sensor B voltage repeated.

Since the system is operating "open loop" or is "coasting" in both the MAN A and MAN B mode of control positions, no adjustments or changes should be made in the cryostat system which would introduce transients during this period of time.

3.8 Remote Temperature Programming

Remote temperature control can be achieved by replacing the internal Kelvin-Varley voltage divider with an external resistive divider connected to J_3 and switching the "TEMPERATURE SET POINT" to the "REMOTE" position. To insure maximum accuracy, the total resistance between pins E-D of J should be equal to 515 ohms. The remote set point connection diagram is shown in Figure 3.5.

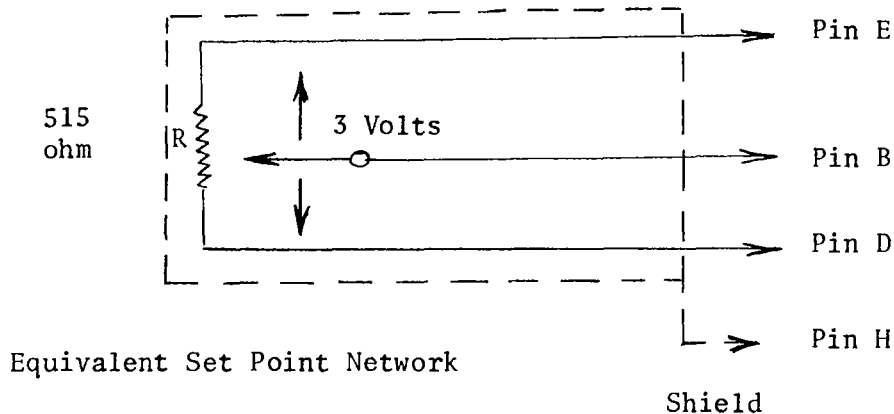

Figure 3.5

A number of external temperature programming networks are shown in Figure 3.6.

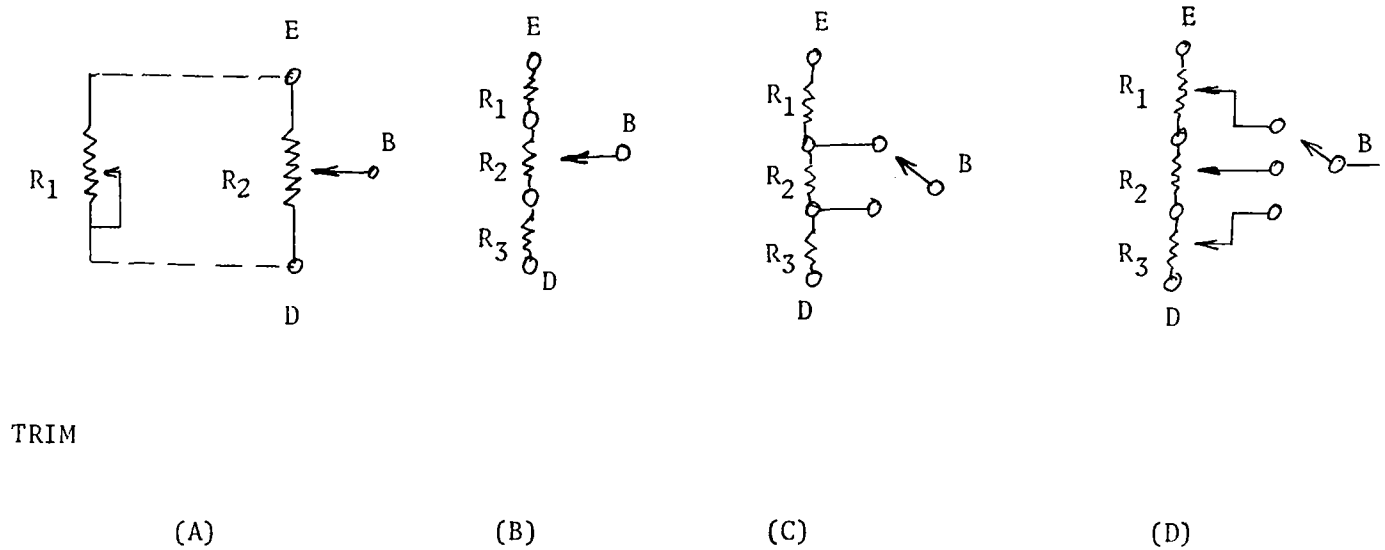

Figure 3.6

The following is a suggested procedure for designing external temperature set point control circuitry:

1. Determine the range of desired temperature control voltage.
2. Choose the most suitable control circuit for your application:
 - a.) Temperature control range

- c.) Fixed temperature set points selected in steps.
- d.) Most flexible arrangement allowing for selected steps and continuously variable temperature set points.

Additional variations of the above may be tailored to fit the intended application.

3. To insure that the total resistance between pins E & D of the external programming voltage divider be of the correct value to develop a drop of 3 volts, it is suggested that the divider calculation be based on approximately 20 ohms per 0.1 volts and a shunting resistor (R_1 in Fig. 3.6 a) used for precision trimming.

The 3.0 volts between pins E-D can be measured with a precision floating voltmeter or calibrated with the DTC-500 internal set point volts switch and 10 turn dial as follows:

- a.) Connect a precision resistor R (any value between 50K-250K) to the pins A-B of the sensor A input plug J (amphenal type 126-217 or equivalent) in place of the sensor as shown in Fig. 3.7, and turn the sensor selector switch on the front panel to Manual A position.

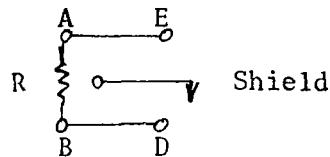

Figure 3.7

The voltage drop across resistor R is equal to $10 \times 10^{-6} \times R$ volts, thus a 100K ohm resistance would result in a 1 volt drop. With the reformer "TEMPERATURE SET POINT" switch on the rear of the instrument, in "INTERNAL" position, the null meter will indicate zero error when the internal temperature set point switch on the front panel is at 1.000 volts. Increase the gain to maximum and adjust the 10 turn dial at the internal set point control if necessary for the null meter to indicate zero. Move the reference set point switch on the rear panel to external position and adjust trim resistor R on the external set point programming instrument so that the null meter reads zero.

The external programming network is now matched to the internal reference source. Although one point calibration as described above is sufficient, it may be desirable to check several points. In that case, a precision resistance divider may be used for R in the sensor input connector, however the leads as well as the divider resistor should be shielded

and the shields connected to pin H of the sensor A input connector (J₁). Similarly, the leads and box housing the externally programmable temperature resistance network should be shielded through pin H of external set point plug (J₃).

3.9 Grounding

The chassis is grounded by the 3 lead power cable to the electrical supply common ground. The common lead of the controller circuitry ("Lo" terminal of the heater output - Key 21, Fig. 3.2) is externally connected to the chassis ground terminal. Although the grounding of the controller common is normal operation practice, the common "Lo" terminal may be disconnected from chassis ground if doing so helps to eliminate accidental ground loops within the system.

SECTION IV

Theory of Operation

4.1 Introduction

This section contains the theory of operation of the DTC-500 Controller and a functional characterization of the controller in Laplace transform notation to aid the thermal system designer in system stability analysis.

4.2 General Description

Refer to Figure 3.3 and Figure 5.2 as an aid in the following discussion. With reference to Figure 3.3, a precision constant current source causes 10 microamperes of current to flow through the sensor diode. The set point voltage source (or bucking voltage) is subtracted from the diode voltage and the difference (or error) signal is amplified in a variable gain amplifier stage (operational amplifier A2 in Fig. 5.1). The amplified error is displayed on the NULL meter and also applied to (1) a gain of 20 amplifier, (2) an integrator circuit and (3) a bound or clamping circuit. The bounding circuit disables the integrator for large errors. The output of the integrator is amplified by a variable gain amplifier whose gain is set by the AUTO RESET potentiometer. The gain range is from 1 to 100. The integrator, bounding circuit, post integrator variable gain amplifier and constant gain of 20 amplifier are associated with operational amplifier A3, transistor Q1 and field effect transistor Q2 in Figure 5.1. The processed error signal drives the output power amplifier circuit whose voltage gain is 2. Operational amplifier A4 and transistors Q3 and Q4 in Fig. 5.1 comprise the power amplifier. The output of the power amplifier is metered by the HEATER CURRENT indicator and passed to the heater element. Closed looped control action is achieved by providing a thermal signal path between the heater element and the temperature sensing diode.

To illustrate the automatic temperature control action, suppose the sensing diode is colder than the programmed temperature setting. The diode voltage will be greater than the set point voltage which results in an error voltage. The greatly amplified error signal causes a current to flow in the heating element which raises the diode temperature and reduces its voltage. As the diode temperature approaches the set point temperature, the error signal is reduced and less power is supplied to the heater element. At some small temperature error (or offset) the power supplied to the heater element is just sufficient to heat the sample holder and diode to maintain a steady but slightly lower temperature. The AUTOMATIC RESET feature of the controller is used to reduce this error to zero. The automatic reset circuit integrates the error and this accumulated signal drives the output power amplifier. The integrator signal continues to grow as long as an error exists. The heater current continues to increase in response to the integrator signal. Eventually the error is driven to zero and the integrator signal assumes a constant value. This signal is precisely the value of heater current required to maintain the error at zero. The integrator capacitor stores or "remembers" this signal as the appropriate heater current level to maintain temperature coincidence between the diode and the set point temperature. In control theory* terminology, the AUTO RESET circuit raises the system type number from zero to one.

*"Feedback Control System Analysis and Synthesis" by John J. D'Azzo and Constantine H. Houpsis, McGraw-Hill Book Co., New York, 1966, Pg. 397.

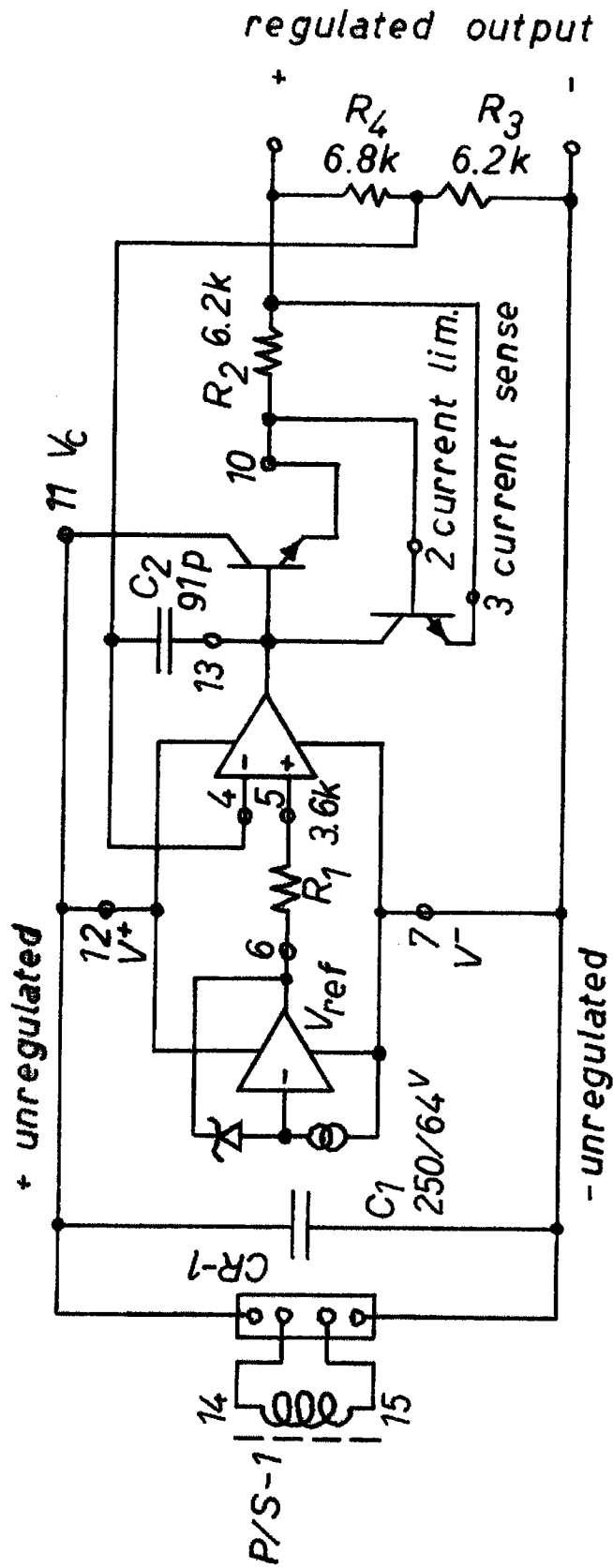
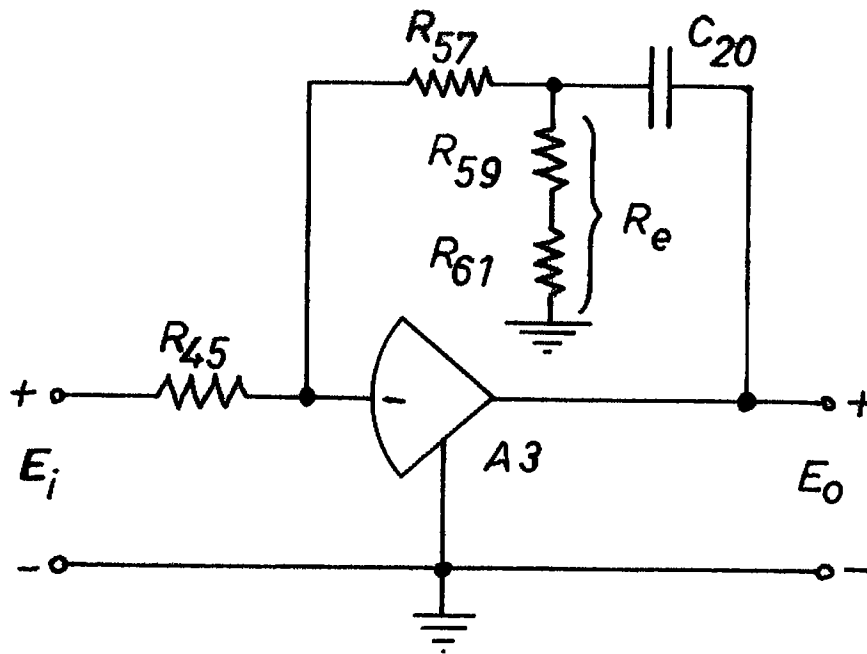

FIGURE 4.1 OPERATIONAL POWER SUPPLY CIRCUIT OF THE FAIRCHILD uA723 TYPE



$$\frac{E_o}{E_i} = - \left[\frac{R_{57}}{R_{45}} + \frac{1}{sR_{45}C_{20}} \left(1 + \frac{R_{57}}{R_e} \right) \right]$$

FIGURE 4.2 SIMPLIFIED EQUIVALENT CIRCUIT OF
AUTOMATIC RESET AMPLIFIER

4.3 Detailed Description

(a) Regulated Power Supplies

There are five, essentially identical, regulated power supplies in the instrument. They are designated as PS-1 through PS-5 in Figure 5.1. Each supply uses an integrated uA723 type Precision Voltage Regulator as its main component. A detailed drawing of one of the supplies is given in Fig. 4.1. A description of this supply should suffice for all the others.

The secondary voltage of transformer T1 appearing at terminals 14 and 15 is rectified by diode rectifier bridge CR1-4 and filtered by capacitor C1. This unregulated voltage is applied to the uA723 power supply leads 12 and 7. The reference voltage op-amp in the uA723 produces a stable, 7.1 volt reference voltage at pin 6. This voltage is externally coupled to the non-inverting input to the regulator op-amp. (pin 5) by resistor R₁. The value of R₁ is chosen to be equal to the parallel combination of R₃ and R₄ to minimize offset errors. Resistors R₃ and R₄ sample a fraction of the output voltage and apply it to the inverting input, pin 4. The regulator op-amp attempts to maintain the potential at pins 4 and 5 equal to one another in spite of variations in the line voltage and load current. The output current is passed through R₂. Automatic current limiting is accomplished by current sampling resistor R₂ and the current shut down transistor connected to pins 2 and 3. If the current through R₂ is excessive, the resulting voltage developed across R₂ causes the transistor to conduct, diverting base current from the series pass transistor.

(b) Diode Constant Current Supply

Referring to Fig. 5.1, power supplies PS-1 and PS-2, and operational amplifier A1 constitute the main components in the diode constant current supply. Due to the high input impedance of the operational amplifier A1, the diode current is forced to flow through resistor R26 developing 4.99V at 10 uAmps. The wiper of potentiometer R23 is positioned so that an equal voltage is developed between the wiper of R23 and the junction of CR-22A and R24. With the wiper so adjusted, any variation in the diode current will result in a differential error voltage. When amplified and applied to the cathode of the sensor diode, this signal will be of such a polarity as to drive the diode current back towards its design value of 10 uAmps.

The entire constant current supply system was designed to be fully floating so that the cathode of the sensor diode might be returned to common.

(c) Set Point Voltage Supply and Divider

Floating power supply PS-3 preregulates the voltage used to supply reference diode CR-13. The doubly regulated voltage appearing between tie point (TP) 5 and the cathode of CR-13 is applied to a 3 stage Kelvin-Varley voltage divider consisting of R101, R117, R28, R29, R33 and R34. The set point voltage proper consists of the potential developed between tie point 5 and the wiper of potentiometer R28.

The floating set point voltage power supply and Kelvin-Varley voltage divider constitute a potentiometer loop. When the set point voltage equals the sensor diode voltage, no error signal appears at the input terminals of preamplifier A2.

(d) Variable Gain Amplifier

The variable gain amplifier shown in Fig. 3.3, with a gain range of 7.5 to 750, is realized by chopper-stabilized operational amplifier A2. The input resistor is R32 and the feedback element consists of R35 and R41 and potentiometer R37 and R38 and resistors R39, R40 and R41.

Diodes CR-26, 27, 28, 29 or R39 and R40 comprise a soft-limiter circuitry. Large signals cause forward biased diodes to conduct which in turn reduces the effective feedback resistance and amplifier gain, and prevents the amplifier from saturating.

The output of amplifier A2 drives the null meter and subsequent stage A3. For small errors, the meter reading is proportional to the error. As the error amplitude increases, either diode CR-35 or CR-36 conducts causing the meter reading to be logarithmic. Cross-over from linear to non-linear deflection occurs at approximately 60% of full scale.

(e) Automatic-Reset Circuit, Bounding Circuit

The bound circuit, integrator, variable gain amplifier (A_v of 1 to 100), and the constant gain of 20 amplifier shown in Fig. 3.3 are realized by operational amplifier A3, bipolar transistor Q1 and field effect transistor Q2 in Fig. 5.1. A simplified equivalent circuit of the stage is given in Fig. 4.2.

Application of the principle that the summing junction currents must add to zero yields the overall transfer function of the stage. The constant gain of 20 amplifier in Fig. 3.3 is represented by the term R_{57}/R_{45} while the variable gain amplifier following the ideal integrator is represented by the term $(1 + R_{57}/R_e)/R_{45}C_{20}$ in the equation in Fig. 4.2.

The bounding circuit disables the integrating function for large errors when rapid corrective action is desired. The memory action of integrating capacitor C20 causes the controller to be sluggish in such transient operations. The method of disabling the capacitor depends upon the sign of the error and the polarity of the voltage across C20. If the voltage across capacitor C17 is of such a polarity as to make TP19 positive with respect to TP17, diode CR-33 conducts reducing the effective gain of the stage and discharging the capacitor.

The second mode of bounding occurs if the error signal at the base of Q1 becomes excessively negative. Q1 is normally biased by CR-30 so that field effect transistor Q2 is cut-off (approximately -9V) at the gate. As the base of Q1 becomes more negative, Q1 conducts current, increasing the collector voltage toward zero. The reduced bias on FET Q2 causes its source-drain impedance to act as a shunt resistor across capacitor C20. This shunting effect discharges the capacitor and converts the ideal integrator action to a type zero action.

The switch S3 is open when the AUTO RESET control is in the off position.

(f) Output Power Amplifier

The processed error signal appearing at TP18 is greatly amplified in power by op-amp A4, Q3, and Q4 before being applied to the heater element. Transistors Q3 and Q4 constitute a Darlington series pass element in a current amplifier circuit. They are inside the feedback loop associated with op-amp A4, R65 being the feedback resistor. The input resistor for the op-amp is R62 so that the voltage gain of the power amplifier circuit is R_{65}/R_{62} or approximately 3.5. At rated output current of one ampere, the voltage appearing at TP20 is -10.5 volts. Use of a heater resistance in excess of ten ohms will reduce the available heater current below the rated maximum value of 1 ampere.

Winding 5-6-7 on transformer T1, diodes CR-22 and CR-23 and capacitor C16 constitutes the power supply for the series pass elements Q3 and Q4.

Power supplies PS-4 and PS-5 are supplies for operational amplifiers A2, A3 and A4, transistor Q1 and FET Q2.

(g) Manual Heater Current Control

When the mode selector switch is set to either MAN A or MAN B position, switch section S1-F connects the input of the power amplifier stage to the wiper

of potentiometer R54. Varying the wiper position from zero to its maximum will vary the voltage at TP20 from zero to -10 volts. The heater element current is thus varied proportionately to the setting of R54 and the maximum heater current switch (S4) position.

(h) Heater Current Metering and Limiting

The heater element current is measured by the heater current ammeter, shunted by resistor R201 through R205 as appropriate for the current range selected. The full scale output current is determined by the series combination of the heater element resistance and one of the group of resistors R206 through R209. This series combination is connected across the nominal -10.5 volt output of the power amplifier. Approximately .5 volts appears across the IMA current meter and R66.

Under no circumstances shall the rating of fuse FU2 be increased above one ampere in an attempt to achieve a power dissipation of ten watts in a heater element whose resistance is less than ten ohms. Such a substitution invalidates the instrument warranty and is likely to damage the output power amplifier circuit.

SECTION V

Maintenance and Troubleshooting

5.1 Introduction

This section contains instructions for maintaining and calibrating the controller, nominal voltage values and gains, circuit schematic diagram, printed circuit board component diagram and parts list.

5.2 Test Equipment and Accessories

An RCA Senior Voltohmst vacuum tube voltmeter or an equivalent high input impedance digital voltmeter; a ten ohm, ten watt resistor to simulate the heater element; and a precision resistor connected to simulate the diode in a connector assembly wired according to Fig. 2.1 (c) are normally sufficient for testing and calibrating the DTC-500 Controller.

5.3 General Remarks

Upon initial installation, the single most probable cause of system malfunction is an improperly connected temperature sensing diode. If it is impossible to zero the null meter at any setting of the set point voltage controls, carefully examine the cable/diode assembly to insure that the diode polarity is correct, that the sensor is plugged into the "SENSOR A" receptacle and that the "TEMPERATURE SET POINT/INTERNAL/REMOTE" slide switch at the rear of the case is in the INTERNAL position.

Because of the highly reliable solid state design of the controller, it is most unlikely that the controller will be a source of difficulty. For this reason, it is advisable to examine other portions of the cryogenic system before testing the controller proper. Some suggested checks are:

- (1) Open or shorted sensor and heater leads, particularly in the vicinity of the sample holder if it is subject to frequent dis-assembly.
- (2) Leakage paths between heater and sensor leads giving rise to electrical feedback in addition to thermal feedback.
- (3) Premature loss of cryogenic fluid due to thermal shorts in dewar, ice blocks in lines, sample holder immersed in cryogen, sample holder in vapor whose temperature is above the controller set point temperature, etc.
- (4) Excessive thermal path phase lags will cause the control loop to be unstable at high gain settings. Physical separation between the diode and heater, particularly by paths of small thermal cross-section should be avoided.
- (5) Examine heater element fuse FU2.

If it is indicated that the controller is malfunctioning after performing the tests to be described below, it is recommended that the instrument be returned to the factory for repair. The components used in the instrument are

costly and may be permanently damaged if subjected to inappropriate test voltages or excessive soldering iron heat. Although premium materials and techniques have been used to fabricate the instrument circuit board, there is always the risk of lifting a connection pad or cracking the board when unsoldering a component.

5.4 Servicing Printed Circuit Boards

It is suggested that components be unsoldered for trouble shooting only as a last resort since ample information is available at the numbered terminal pins. Attempt to infer component currents by voltage tests rather than removing a lead and seriesing it with an ammeter. All voltages are available for measurement from the top side of the printed circuit board. Therefore, the board need only be removed when it is necessary to replace a component. To remove the printed circuit board, unscrew the bolts from the bottom of the case which attach the board to the stand-off studs.

Swing the rear of the board up, using the front edge as a pivot. Be sure to clear the line cord retainer and fuse holders. Be sure to support the board in the raised position. If the board is stressed, it may break or develop hairline cracks in the printed wiring.

Use a low heat (25 to 50 watts) small-tip, freshly tinned soldering iron. Use small diameter, rosin core solder. Remove a component lead by applying heat to the lead, observing the solder melt and then pulling the lead through the board from the top side. Never apply tension to printed wiring from the bottom side.

Thoroughly clean all of the old solder from the mounting hole before inserting a new component with the use of a wick or desoldering suction device. Shape the new component and insert in mounting hole. Do not use heat or force to insert the new component. If the leads will not go through the hole, file the lead or clean the hole more thoroughly. Once mounted properly, apply heat to lead and wiring pad simultaneously and resolder. Clean excess flux from the connection and adjoining area with warm water and weak detergent if need be. (Contamination in some areas of the board can seriously degrade the high input impedance of the operational amplifiers.)

5.5 Operational Checks

Replace the sensor diode connector plug with a test plug made up according to Fig. 2.1 (c). Substitute a precision resistor for the sensor diode in the test plug. Remove the heater element leads and place a ten watt, ten ohm resistor across the heater output terminals.

Ten microamperes flowing through the test resistor should develop a potential of 1.00 volts across a 100 K ohm resistor. With the gain set at maximum position and the mode selector switch in position MAN A (assuming the test plug is in SENSOR A receptacle), attempt to null the error with a set point voltage in the vicinity of 1.0 volts. The null meter should swing smoothly as the set point voltage vernier is varied in the vicinity of the null.

While still in the MAN A position, set the MAXIMUM HEATER AMP switch at 1 amp. Vary the MAN. RESET potentiometer from zero towards its maximum. The current meter should increase linearly along with the advance of the MAN RESET control. With the MAN RESET control set to give mid-scale heater current meter deflection, rotate the MAX HEATER AMP switch through all of its positions. The heater current meter indication should remain approximately at mid-scale in all of the positions.

Zero the null meter with the set point voltage controls. Turn the AUTO RESET and GAIN controls to mid-scale position. Set the MAX HEATER CUR. switch to 1 amp. Position the mode control switch to AUTO A. Abruptly rotate the set point voltage vernier counter clockwise sufficiently to cause a -10 unit deflection of the NULL meter. The heater current meter deflection will consist of two components. The first is a rapid step rise due to the steady null error and a second, gradually rising component due to the AUTO RESET circuit integrating the steady error. The heater current meter will gradually rise towards full scale deflection. The rate at which the heater current rises is determined by the AUTO RESET time constant setting. The rate is a minimum in the counterclockwise position and a maximum in the fully clockwise position.

Abruptly rotate the set point voltage vernier clockwise to cause +10 units deflection of the NULL meter. The HEATER CURRENT meter should gradually decrease from full scale deflection to zero. The rate at which the current meter goes to zero is in part determined by the bounding circuit. Its non-linear behavior accounts for the asymmetry in the temperature versus time characteristics as shown in Fig. 3.4.

If the instrument responds to the tests outlined above as indicated, either the trouble lies elsewhere in the system or the malfunction in the controller is of a subtle nature. As an aid in trouble shooting in the latter case, typical voltages and gains under specified conditions are given in Section 5.6.

5.6 Nominal Voltages and Gains

The following voltage measurements were made with an RCA Senior Voltohmmeter. A 1%, 75K resistor was used to simulate the diode and a 10 ohm, 10 watt resistor was used in place of a heater element.

The voltage across the input filter capacitors C1, C4, C7, C10 and C13 in power supplies PS-1 through PS-5 nominally 24 volts with nominal line voltage. The output voltage which appears between terminals 3 and 7 of the uA723 integrated circuits is 15 volts. The sampling resistors are proportional so that the potential between pin 4 and pin 7 is approximately 7 volts.

Reference diodes CR-37 and CR-13 are reverse biased at 6.4 volts.

The voltage appearing across capacitor C16 in PS-6 varies between approximately 14 and 20 volts, depending upon the heater element current. At no load the voltage is 20 volts, decreasing to 14 volts at 1 ampere output.

The emitter of Q1 is biased to +0.5V to compensate for the turn on voltage of Q1.

The output power amplifier stage may be checked by placing the mode selector switch in the MAN A position. The potential across R54 (terminals 6 to 7) is 3.4 volts. The voltage at terminal 20 should be approximately 3.5 times the voltage selected between the slider of R51 and ground. The voltage at the output of amplifier A4 is about one volt more negative than the voltage at terminal 20 because of the base emitter drops of Q3 and Q4.

With the AUTO RESET control in the off position (in the switch detent) and the MAX HEATER CUR switch in the 1 amp. position, the total voltage gain of amplifiers A3 and A4 may be inferred. The CURRENT METER corresponds to a 10 volt full scale voltmeter if a 10 ohm heater element is used. Comparison of the incremental output voltage change to the corresponding incremental NULL meter error change will yield the gain. The nominal cascade gain of the last two stages is 40.

Gain checks should be performed by first zeroing the NULL meter with the SET POINT VOLTAGE VERNIER. A small voltage change is made in the vernier dial setting and the resulting changes in the NULL meter and CURRENT meters observed.

5.7 Calibration of Set Point Voltage

The instrument has been carefully calibrated to within 100 mV and residual base line resistance of the 10 turn potentiometer R28. Should it be desirable to check or recalibrate the set point reference voltage, the sensor should be disconnected and the "TEMPERATURE SET POINT" switch on the back panel be in the "INTERNAL" position. The reference voltage may be measured across pins E-D of the sensor connectors J₁ or J₂ without opening the core. Voltage measurements should be taken with a high precision potentiometric instrument. If recalibration is indicated, after allowing a minimum of 20 minutes warm-up time, remove the cover and adjust trimmer R33 so the voltage between terminal pins 5 and 3 should be within 3.0000 ±100 uV.

5.8 Calibration of Sensor Current

The sensor current has been factory calibrated to 10 microamperes ± 10 nanoamperes. To check the sensor current without removing the case cover, a conveniently available precision resistance of not less than .01% tolerance should be connected to pins A-B of the sensor connector socket (J₁ or J₂), and the sensor selector switch on the front panel switched to the appropriate sensor input (A or B). The "TEMPERATURE SET POINT" switch on the rear panel should be switched to "REMOTE".

A high quality potentiometric voltmeter connected to the precision resistor should measure a voltage equal to 10 microamperes times the value of the resistor. Typically, a 100K ±.01% resistor should read 1.0000 within 100 microvolts. If recalibration is indicated, the voltage drop across the precision resistors can be measured, after removing the case cover and adjusting trimmer R23 on the circuit board.

5.9 Parts List, Component Location Diagram and Schematic

Table 5.1

PARTS LIST

REF. DESG.	DESCRIPTION			LAKE SHORE PART NO.
R1	3.6K	1/4W	10%	
R2	6.2 ohms	1/4W	5%	
R3	8.2K	1/8W	1%	(NOMINAL)
R4	7.5K	1/8W	1%	
R5	3.6K	1/4W	10%	
R6	6.2 ohms	1/4W	5%	
R7	8.2K	1/8W	1%	(NOMINAL)
R8	7.5K	1/8W	1%	
R9	3.6K	1/4W	10%	
R10	6.2 ohms	1/4W	5%	
R11	8.2K	1/8W	1%	(NOMINAL)
R12	7.5K	1/8W	1%	
R13	1.24K	1/8W	1%	
R14	3.6K	1/4W	10%	
R15	6.2 ohms	1/4W	5%	
R16	8.2K	1/8W	1%	(NOMINAL)
R17	7.5K	1/8W	1%	
R18	3.6K	1/4W	10%	
R19	6.2 ohms	1/4W	5%	
R20	8.2K	1/8W	1%	(NOMINAL)
R21	7.5K	1/8W	1%	
R22	7.5K	1/8W	1%	
R23	5K TRIMPOT, HELIPOT	58PR5000		
R24	30.9K	1/8W	1%	
R25	50K	1/8W	1%	(NOMINAL)
R26	499K	1/8W	.1%	
R27	100K	1/4W	5%	
R28	100 ohms 10 TURN POT.	HELIPOT 7216		
R29	TRIM RESISTOR			(NOMINAL)
R30	3.48K	1/8W	1%	
R31	470	1/8W	1%	
R32	100K	1/4W	5%	
R33	10 TRIMPOT, HELIPOT	78PR10		
R34	579	1/4W	1%	
R34A				(NOMINAL)
R35	22 MEG	1/4W	5%	
R36	560	1/4W	5%	
R37	10K POTENTIOMETER			(GAIN CONTROL)
R38	100	1/8W	1%	
R39	100	1/4W	5%	
R40	10K	1/4W	5%	
R41	20K	1/4W	5%	
R42				(NOMINAL)

REF. DESG.	DESCRIPTION			LAKE SHORE PART NO.
R43				(NOMINAL)
R44	470	1/4W	5%	
R45	330K	1/4W	5%	
R46	8.65K	1/8W	1%	
R47	18K	1/4W	5%	
R48	100K	1/4W	5%	
R49	1.5K	1/4W	5%	
R50	12K	1/4W	5%	
R51	33K	1/4W	5%	
R52	680K	1/4W	5%	
R53	2.7 MEG	1/4W	5%	
R54	1K TEN TURN POT			(MANUAL RESET)
R55	3.83K	1/8W	1%	
R56	2.7K	1/4W	5%	
R57	1 MEG	1/4W	5%	
R58	1.2K	1/4W	5%	
R59	1 MEG POT			(AUTO RESET CONTROL)
R60	1K	1/4W	5%	
R61	10K	1/4W	5%	
R62	16.2K	1/4W	1%	
R63	50K	1/8W	1%	(NOMINAL)
R64	12K	1/4W	5%	
R65	56K	1/4W	5%	
R101-104	17.61	1/8W	.05%	SET POINT
R105-106	TRIMMING RESISTORS			VOLTAGE DIVIDER
R107-117	48.7	1/8W	.05%	ASSEMBLY
R200	430	1/8W	1%	
R201	54.9	1/4W	1%	HEATER CURRENT
R202	16.9	1/8W	1%	RANGE AND
R203	5.0	1/8W	1%	METER SWITCH
R204	1.65	1/2W	1%	ASSEMBLY
R205	4.995	1W	1%	
R206	1000	1/4W	1%	
R207	324	1/2W	1%	
R208	90	2W	1%	
R209	23.33	5W	1%	

REF. DESG.	DESCRIPTION	LAKE SHORE PART NO.
C1	220 MFD, 63 VDC, Electrolytic	
C2	91 pF Mica DM10	
C3	OPTIONAL 25 MFD, 25 VDC, Electrolytic	
C4	220 MFD, 63 VDC, Electrolytic	
C5	91 pF Mica DM10	
C6	OPTIONAL 25 MFD, 25 VDC, Electrolytic	
C7	220 MFD, 63 VDC, Electrolytic	
C8	91 pF Mica DM10	
C9	OPTIONAL 25 MFD, 25 VDC, Electrolytic	
C10	220 MFD, 63 VDC, Electrolytic	
C11	91 pF Mica DM10	
C12	OPTIONAL 25 MFD, 25 VDC, Electrolytic	
C13	220 MFD, 63 VDC, Electrolytic	
C14	91 pF Mica DM10	
C15	OPTIONAL 25 MFD, 25 VDC, Electrolytic	
C16	2500 MFD, 25 VDC, Electrolytic	
C17	.22 MFD, 100 VDC, Mylar	
C18	.68 MFD, 50 VDC, Mylar	
C19	.22 MFD, 50 VDC, Mylar	
C20	100 MFD, 15 VDC, Tantalum	
C21	470 pF, 100 VDC, Mica	
C22	.01 MFD, 50 VDC, Mylar	
CR1-12	SILICON RECTIFIER IN4002	
CR13	REFERENCE DIODE IN4571A	
CR14-21	SILICON RECTIFIER IN4002	
CR22	SILICON RECTIFIER IN1612	
CR23	SILICON RECTIFIER IN1612	
CR24	SILICON PROTECTION DIODE	411
CR25	SILICON PROTECTION DIODE	411
CR26	SILICON DIODE	411
CR27	SILICON DIODE	411
CR28	10 V. REFERENCE DIODE IN961	
CR29	10 V. REFERENCE DIODE IN961	
CR30	SILICON DIODE	411
CR31	3.9 V.	DZ 7011
CR32	SILICON DIODE	411
CR33	SILICON DIODE IN841	
CR34	SILICON DIODE	411
CR35	IN358	
CR36	IN358	
CR37	REFERENCE DIODE IN4571A	
A1	OPERATIONAL AMPLIFIER	5825
A2	OPERATIONAL AMPLIFIER	5823
A3	OPERATIONAL AMPLIFIER	5825
A4	OPERATIONAL AMPLIFIER	5824

REF. DESG.	DESCRIPTION	LAKE SHORE PART NO.
M1	VOLT. REG., 6W7723393	
M2	VOLT. REG., 6W7723393	
M3	VOLT. REG., 6W7723393	
M4	VOLT. REG., 6W7723393	
M5	VOLT. REG., 6W7728393	
Q1	2N3638	
Q2	2N5459 FET TRANSISTOR	
Q3	2N4234	
Q4	2N4901	
S1	MODE SELECTOR SWITCH	
S2	SET POINT SWITCH ASSEMBLY	
S3	PART OF POTENTIOMETER R55	
S4	HEATER CURRENT METERING SW. ASSEMBLY	
S5	POWER SW., A.H. & H. 81024-GB	
S6	LINE VOLTAGE SELECTOR SWITCH, SWITCHCRAFT 46256LF	
S7	TEMP. SET POINT SELECTOR SWITCH, SWITCHCRAFT 46206L	
FU1	FUSE HOLDER, LITTLEFUSE 342004	
FU2	FUSE HOLDER, LITTLEFUSE 342004	
HS1	HEATSINK, WAKEFIELD ENG., MODEL 690-3-BA	
HS2	HEATSINK (CR6), WAKEFIELD ENG., MODEL 695-B	
HS3	HEATSINK (CR7), WAKEFIELD ENG., MODEL 695-B	
J1	5 PIN SENSOR SOCKET, AMPHENOL 126-218	
J2	5 PIN SENSOR SOCKET, AMPHENOL 126-218	
J3	7 PIN REMOTE SET POINT, AMPHENOL 126-198	
J4	HEATER BINDING POST, E.F. JOHNSON, 111-0113-001	
J5	HEATER BINDING POST, E.F. JOHNSON, 111-0103-001	
J6	CHASSIS GROUND POST, E.F. JOHNSON, 111-0103-001	

REF. DESG.	DESCRIPTION	LAKE SHORE PART NO.
T1	POWER TRANSFORMER	T-25-29
PL1	PILOT LIGHT ASSEMBLY, INDUSTRIAL DEVICES 1040A87	
MT1	NULL METER -100-0-100 μ Amp.	
MT2	CURRENT METER 0-1 MilliAmp.	
DL1	10 TURN DIAL FOR R28, HELIPOT	2607
DL2	10 TURN DIAL FOR R54, HELIPOT	2607

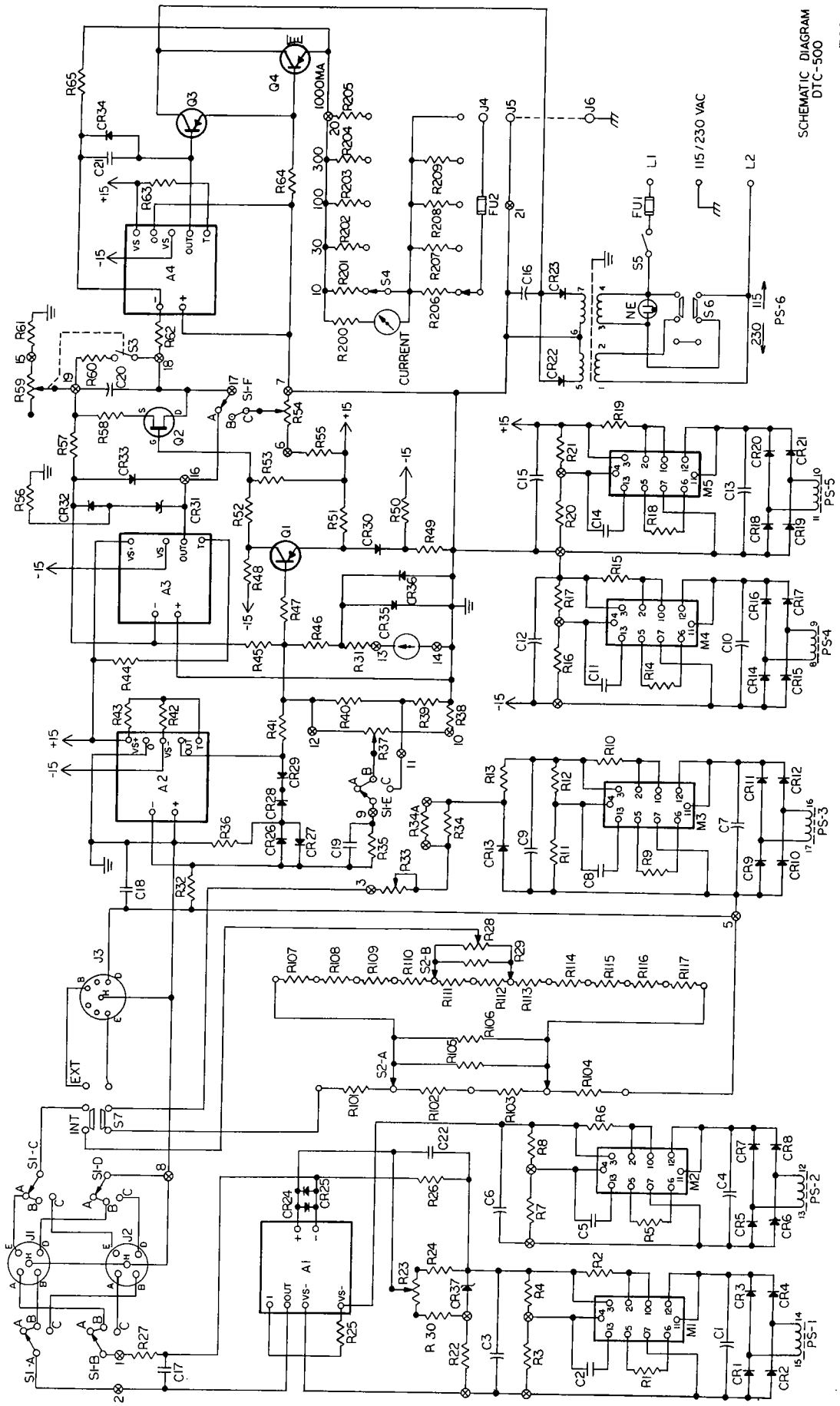

SCHEMATIC DIAGRAM
DTC-500

7229

